

Digiroad Description of Data Objects

Publication 2/2018 (3.9.2018)

Table of Contents

1	Welcome!	4
2	Glossary	4
3	General information on Digiroad	7
	3.1 Data sources and data collection	7
	3.2 Data quality	8
	3.3 Data structure in Digiroad.....	8
	3.3.1 Road link.....	8
	3.3.2 Linearly referenced attribute data.....	9
	3.4 Coordinate reference systems and height systems	10
	3.5 Release and delivery formats.....	10
	3.5.1 Digiroad R.....	11
	3.5.2 Digiroad K.....	12
	3.5.3 WMS and WFS interfaces (beta).....	13
	3.5.4 TN-ITS interface	13
4	Digiroad data objects	13
	4.1 Road link attribute data	14
	4.1.1 Administrative class	14
	4.1.2 Functional class	14
	4.1.3 Direction of traffic flow.....	16
	4.1.4 Road link type	17
	4.1.5 Bridge, underpass or tunnel	17
	4.1.6 Address data	18
	4.1.7 Road address data.....	19
	4.1.8 Geometric accuracy	19
	4.1.9 Digitisation direction in relation to the geometry of National Land Survey of Finland.....	20
	4.1.10 Link phase	21
	4.1.11 Source of the link geometry	21
	4.1.12 Other attribute data of the road link.....	21
	4.2 Restricted manoeuvre.....	22
	4.3 Point attribute data	23
	4.3.1 Public transport stop	24
	4.3.2 Barrier.....	26
	4.3.3 Traffic light	27
	4.3.4 Pedestrian crossing.....	27
	4.3.5 Directional traffic sign	28
	4.3.6 Railway crossing	29
	4.3.7 Forest road turnaround point (pilot)	29
	4.4 Line attribute data	30
	4.4.1 Speed limit.....	31
	4.4.2 Maximum allowed ... x 7	32
	4.4.3 Lit road	33
	4.4.4 Paved road.....	33
	4.4.5 Road affected by thawing.....	33
	4.4.6 Width.....	34

4.4.7	Traffic volume	34
4.4.8	Vehicle specific restriction	34
4.4.9	Restriction for the transportation of dangerous goods (VAK)	36
4.4.10	Number of lanes	36
4.4.11	Public transport lane	37
4.4.12	E-road number	38
4.4.13	Exit number	38
4.4.14	Winter speed limit	38
4.5	Other features	39
4.5.1	Service	39
Appendices	1
	<i>Appendix 1. Description of data content - field names, data types and code values</i>	<i>1</i>
	<i>Appendix 2. Public transport stop facility data and other attribute data</i>	<i>31</i>
	<i>Appendix 3. Primary data sources by data objects</i>	<i>33</i>
	<i>Appendix 4. Route type</i>	<i>36</i>
	<i>Appendix 5. Time domain character string</i>	<i>37</i>

1 Welcome!

Digiroad is a national database that contains the geometry of the Finnish road and street network featured with the most important road attribute data.

This document provides a detailed description on the Digiroad data features.

More info on Digiroad can be found at our website:
<https://www.liikennevirasto.fi/web/en/open-data/digiroad>

We are happy to help with all matters concerning Digiroad:
info(a)digiroad.fi
tel. +358 40 507 2301

2 Glossary

Digiroad Information System

The Digiroad information system is a national road and street database for which Finnish Transport Agency is responsible and which includes centre line geometry of streets and roads and traffic attribute data.

JHS

Central and local government information management is governed by JHS recommendations (Public Administration Recommendation). JHS refers to a uniform method, specification or guideline issued for the use of central and local government administration.

Centre line geometry

Digiroad centre line geometry is formed by line segments that describe the positions of centre lines of roads, streets, pedestrian and cycle lanes and ferry connections.

Traffic network

Traffic network is an entity consisting of road links connected to each other with nodes. The Digiroad traffic network is topologically consistent, with the exception of certain road links, for examples on islands.

Linear referencing

Linear referencing is a method of indirect spatial referencing in which a position is located by a known point in a linear reference frame (a road link in Digiroad).

Linear reference frame

Linear reference frame is a line geometry from which position in relation to a known

point on a line can be determined, for example according to a measure value like in Digiroad.

Linearly referenced object

Linearly referenced feature is a section in the Digiroad road network without a geometry. The feature is located from the road network dynamically by measure values.

Measure value, M value

Measure or M value is attribute data of linear geometry that helps to define the position on a line unambiguously.

Attribute data

Attribute data is an entity of identifiable, timetable and descriptive properties of a feature. Data objects themselves are attribute data for the road network. In addition, there are data object specific attribute data, such as the type of public transport stop and validity direction.

Features of traffic system

A feature of traffic system is an independent part of the system. For example, a public transport stop is a feature of traffic system with its unique attribute data. The position of the feature may be saved by linear referencing or it may have a position outside the traffic system, indicated by coordinate data.

Point attribute data

Point attribute data refers to attribute data that have a point as the geometric shape of its position. Point attribute data has no M value, with which it could be referenced on the road link geometry. That makes point attribute data separate from the road network. In Digiroad, point attribute data refers to a service.

Point segment

Point segment refers to attribute data whose indirect position is a location in the road link, i.e. a measure. The geometric shape, formed by linear referencing of the attribute data, is a point.

Segment

In Digiroad, a segment refers to road link attribute data that has no geometry of its own. A segment is dynamically located in the road link with M values. There are point and line segments.

Position

In Digiroad, position refers to feature attribute data given by coordinates.

Road link

A linear data object describing the traffic network geometry.

Road link attribute data

Road link attribute data refer to attribute data describing a road link across its entire length. Road link attribute data include data such as functional class, direction of traffic flow and Link-ID.

Data object

Data object refers to traffic network attribute data such as a speed limit or a public transport stop.

Line segment

Line segment refers to attribute data whose indirect position is the distance between two measures on a road link. Line is the geometric shape formed by linear referencing of attribute data.

3 General information on Digiroad

Digiroad is a national road and street information system which includes centre line geometry of streets and roads, traffic attribute data and the features of the traffic system.

Centre line geometry includes vehicle accessible roads, ferry and cable ferry connections for vehicles, and separate pedestrian and cycle lanes.

Traffic attribute data refer to data such as speed limits, permitted traffic flow directions as well as weight and height limits.

Digiroad data can be applied to e.g. services, analyzes and applications related to traffic and navigation.

This document describes the structure and data objects of Digiroad. In this description, data objects have been divided into attribute data of road links, point attribute data, and linear attribute data.

Name and identifiers	Digiroad, FI1000018
References	INSPIRE Data Specification on Transport Networks (17 th April 2014) INSPIRE Generic Conceptual Model (18 th June 2010) JHS 177 Paikkatietotuotteiden määrittely (21 st October 2010)
Information about definition	Name: Digiroad Date: 23 rd May 2016 Author: Finnish Transport Agency (FTA) Language: Finnish
Metadata	http://paikkatietohakemisto.fi/geonetwork/srv/fi/metadata.show?uuid=34155a94-b58b-4ad0-87e6-f96d2db0f3ba (material behind the link in Finnish)

3.1 Data sources and data collection

The National Land Survey of Finland, the Finnish Transport Agency, municipalities, and a few other authorities provide source data for Digiroad. Digiroad data covers the entire Finland. Data collection is based on the Law of the data system of road and street network 28.11.2003/991. The primary data sources are specified according to the data objects in [Appendix 3](#). The Digiroad operator is responsible for harmonizing and integrating the material produced by different vendors into one country-wide material.

3.2 Data quality

For the time being, quality reports or other documents related to data quality are not published regarding Digiroad data objects.

Coverage and accuracy	Digiroad data covers the entire Finland. The quarter who utilizes the data should take into account that the maintenance of Digiroad data objects by municipalities is varied. Therefore, the data quality in different parts of the material varies considerably. The road network data is mostly maintained in the road register by the Finnish Transport Agency. This data may also vary regionally.
Logical integrity	The data is conceptually and topologically sound.
Geometric accuracy	The geometric accuracy of the road links is approximately 3 metres.
Temporal accuracy	The date when the geometry has been extracted from the NLS topographic database is announced when the material is released. All features in Digiroad data have a last modified date in the release. Digiroad data is maintained continuously.
Thematic accuracy	Not known

3.3 Data structure in Digiroad

The Digiroad information system contains information on the centre line geometry of the road network as well as traffic attribute data. The centre line geometry of the Digiroad network of roads and streets consists of road links joined together with nodes. Each road link has a node at both ends. With regard to geometry, road links are linear objects whereas nodes are point objects.

3.3.1 Road link

A road link is the basic unit of centre line geometry. As regards their length, road links usually cover the distance between intersections but they can also be shorter. Road links may be split between intersections if an administrative class or road link attribute data (name, surface type) changes. A more detailed description of road links can be found in the [JHS188](#) recommendation. The length of road links is already defined in the NLS topographic database in which the road links utilized in Digiroad are maintained. Some of the data objects in Digiroad are attribute data of road links, and these attribute data always cover the length of the entire road link. Examples of such data objects are road name, road address, and traffic flow direction.

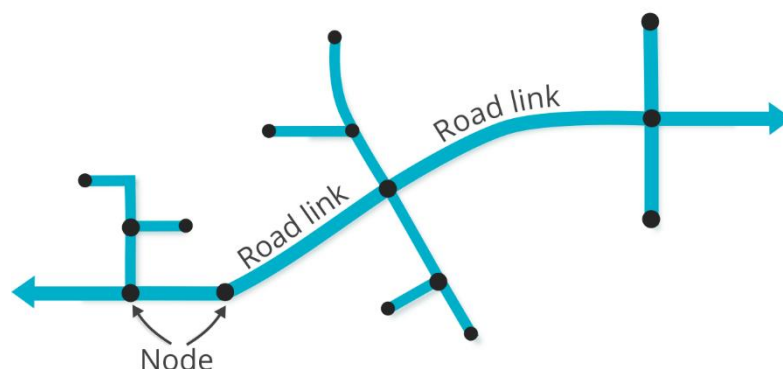

Digiroad network of roads and streets consists of road links.

An M value has been attached to the geometry of a road link. The M value and the road link are used for locating attribute data by means of linear referencing.

3.3.2 Linearly referenced attribute data

Some of Digiroad's data objects are attribute data that have been attached to road links by means of linear reference frame. These data objects can be either linear or point-form, and they need not be of the same length as the entire road link. Linearly referenced attribute data do not have their own geometry but refer to a road link and a position on the road link. In Digiroad, however, a geometry has been generated for each attribute data based on road link geometry.

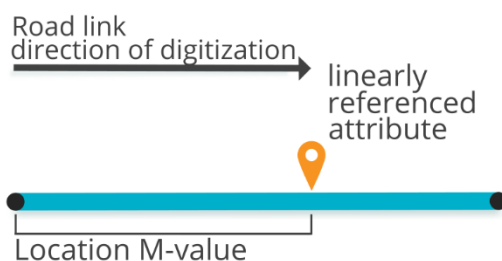

Linearly referenced point attribute data for road links (e.g. public transport stop).

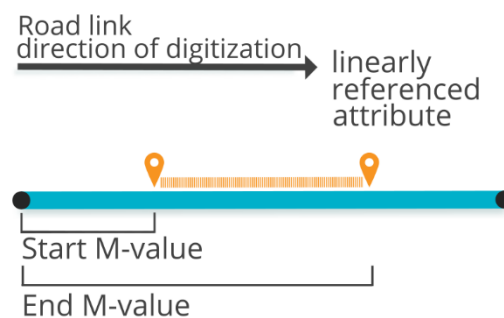

Linearly referenced line attribute data for road links (e.g. speed limit).

The M value represents a position on the road link, i.e. the distance from the start point of the road link. The start M value determines the distance from the start point of the road link to the start of the attribute data, and the end M value determines the distance from the start point of the road link to the end of the attribute data. A single M value refers to point reference data whereas line attribute data has both start and end M values. The start M value for all road links is 0. Moreover, the start M value is a calculatory measure and does not directly correspond to e.g. the actual length of a road link in metres although the difference is usually not significant.

3.4 Coordinate reference systems and height systems

Digiroad uses the EUREF-FIN coordinate reference system as well as the ETRS-TM35FIN projection (EPSG: 3067) which is based on UTM projection. Moreover, Digiroad uses a rectangular coordinate system in which coordinate points have a north coordinate and an east coordinate. The coordinates are given in metres and marked with letters 'P' and 'I'. The heights of road network objects in Digiroad are based on height data in the topographic database, and the height data derives from elevation model 2 m which covers the whole of Finland. If elevation model 2 m is unavailable, the height data will be derived from elevation model 10 m.

As the EUREF-FIN coordinate reference system deviates from the WGS84 coordinate reference system by less than one metre, the two systems can be considered congruent for most purposes.

3.5 Release and delivery formats

The latest Digiroad data can be downloaded from the Finnish Transport Agency's distribution service for open datasets:

<https://aineistot.liikennevirasto.fi/digiroad/latest/>.

Previous releases are available in the same distribution service:

<https://aineistot.liikennevirasto.fi/digiroad/>.

The file format for extracted data is ESRI Shapefile. From publication 2/2018 onwards the data is available also in GeoPackage format.

The data itself is released in two different exports:

- Digiroad R export, files according to the export area
- Digiroad K export, files according to the export area

Both delivery formats contain road link geometry as well as linear and point data objects as their own separate shapefiles. Thus, each data object and its attribute data can be utilized as independent material.

Both delivery formats have the exact same data content as regards data objects and their attribute data.

Below is a more detailed description of the characteristics of both delivery formats.

3.5.1 *Digiroad R*

[Digiroad R](#) is a delivery format in which the length of both road link geometry and linear data objects generally equals to the distance between intersections. Point objects do not split road links or linear objects.

When necessary, data objects can be attached to road links by linear referencing. The referencing process utilizes the LINK_ID tag included in each shapefile as well as the m-values for objects. The location of linear objects as well as the start and end points of their length is given as m-values.

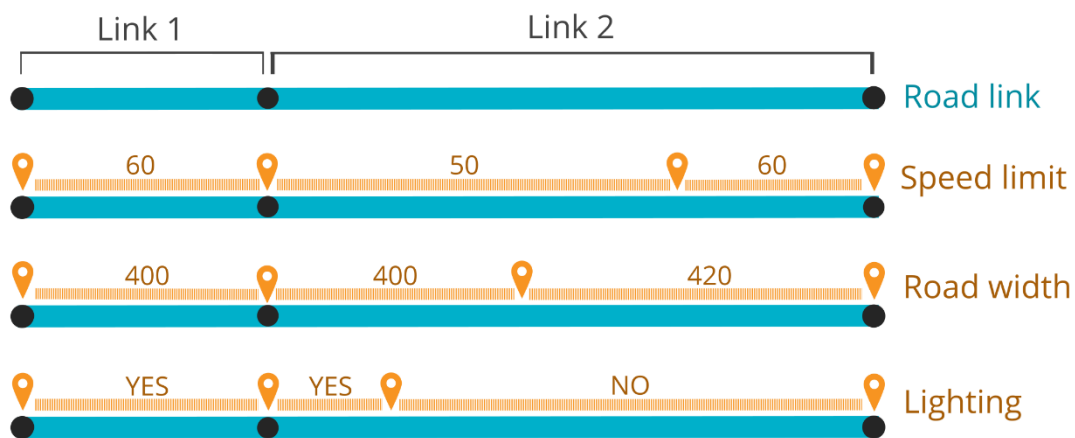

In Digiroad R, the position of data objects has been referenced linearly.

3.5.2 Digiroad K

[Digiroad K](#) is a delivery format in which road links and shapes that contain linear data objects have been formed in the way that the geometry of **both road links and all data objects** is split if any attribute data changes. Consequently, the data may also contain very short links. Point data objects do not, however, split the geometry of road links or linear data objects. The split links have the same link_ID if they form a single uniform object in the topographic database (or in Digiroad R). Furthermore, the split links have been identified by a separate identifier, SEGM_ID.

This identifier consists of the code or number for the municipality where the segment is located as well as a consecutive number generated in the splitting order. If the links in the image below were located in the Helsinki area, their segment IDs would be as follows: LINK_ID = 1; SEGM_ID = 91_1, LINK_ID = 2; SEGM_ID = 91_2, 91_3, 91_4, 91_5). The same SEGM_ID is inherited to all shapefiles describing different data objects. The identifier for a disconnected link is delivery-specific.

The delivery format of Digiroad K export is suitable for use with e.g. MapInfo (version 7 or later).

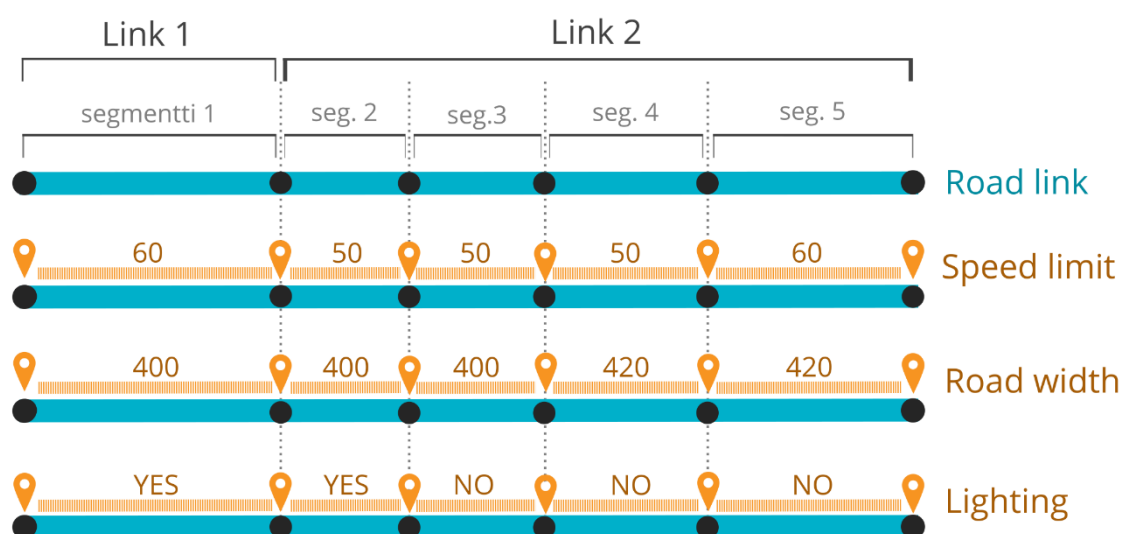

In Digiroad K, the road links have been split into homogenous parts based on their attribute data.

3.5.3 WMS and WFS interfaces (beta)

Digiroad is also published by data objects through the WMS and WFS interfaces in the FTA's viewing and downloading service. The interface services are now in beta phase.

3.5.4 TN-ITS interface

Changes related to speed and weight limits in Digiroad data are released once a day as an xml file through the TN-ITS interface. A link to the interface can be found on the [Digiroad website](#).

4 Digiroad data objects

This chapter provides information on the data objects used in the new Digiroad system. The definition of the object, attribute data, code values and data type of attribute data, and data coverage are given for each data object.

For the fields corresponding to the attribute data in the Digiroad export, please see [Appendix 1, Description of data content](#).

4.1 Road link attribute data

The Digiroad traffic network includes vehicle accessible roads, vehicle tracks, ferry and cable ferry connections for vehicles, and separate pedestrian and cycle paths. The road link geometry is provided by the National Land Survey of Finland. The road link attribute data applies to the entire distance of a road link.

4.1.1 Administrative class

Definition

The administrative class assigns a state, municipality or private owner to a road link. The administrative class does not describe which municipality or road association owns the road. The administrative class is maintained by the National Land Survey of Finland from the beginning of 2016.

Coverage

Data is included for all road links excluding pedestrian and cycle paths and vehicle tracks.

Abbreviation in the Road Link table

[HALLINN LK](#)

Administrative class		
Owner type	Code value	Description
State	1	Road is owned by the state (road).
Municipality	2	Road is owned by a municipality (street).
Private	3	The road is privately owned, for example by a road association.
	99	No data

4.1.2 Functional class

Definition

The functional class describes the importance of a route for traffic. Functional class describes:

- Service level of route to the traffic
- Intention of the route maintainer to direct traffic to the route.

The functional classes of roads *largely* follow the Finnish Transport Agency's road classification (class I, class II, regional and connecting roads). Functional classes of streets may be determined by municipalities. The basis for the classification is the one used in the land use plan. If a road continues as a street, municipal boundaries and the functional class of the road also affect the classification. The functional classes of private roads are determined in accordance with the importance, width and condition of the road.

Coverage

Data applies to all road links.

Abbreviation in the Road Link table

[TOIMINN LK](#)

FUNCTIONAL CLASS		
Functional class	Code value	Description
Class I main road or regional main street	1	<p>Main roads are the principle roads in the Finnish road network. In the Finnish road numbering system, main roads are numbered from 1 to 39.</p> <p>Regional main street serves mainly long distance or transit traffic and incoming traffic. There may also be traffic within the municipality on a regional main street. In terms of traffic, more important than code value 2 regional main street.</p>
Class II main road or regional main street	2	<p>Class II main roads are part of the Finnish road network complementing the class I network and serving regional traffic. Together with the class I main roads they form the network of Finland's main roads.</p> <p>Regional main street serves mainly long distance or transit traffic and incoming traffic. There may also be traffic within the municipality on a regional main street.</p>
Regional road or local main street	3	<p>Regional roads belong to the Finnish road network serving regional traffic and providing connections to class I and II main roads.</p> <p>Local main street serves mainly traffic within a municipality, e.g. from a suburb to the city centre or the traffic between different surrounding areas. There may also be long-distance, transit or incoming traffic on a local main street.</p>
Connecting road or collector street	4	<p>Connecting roads are roads in the Finnish road network that are not class I or II main roads or regional roads.</p> <p>Collector street collects traffic from a traffic cell to main streets and roads. There should be no through traffic on collector streets in the traffic cells.</p>
Feeder street or class I private road	5	<p>Feeder street connects land use with collector streets and roads. There is a direct connection from a feeder street to a plot of land or a building site.</p>

		The use of class I private road is commonly allowed and it can be used throughout the year. Typically a class I private road is very important for the traffic in the area and there is also a road association that has been established and it has received funds from the state or municipality.
Class II private road	6	Class II private roads include all other private roads, excluding private and forest roads, which are not in class I private roads and which are accessible by vehicles.
Vehicle track	7	Vehicle tracks are other private or forest roads, which may not be accessible by car but can be used by pedestrians, bicycles or off-road vehicles. Vehicle tracks can connect with the road network without a common end point. This is a new class added to the Digiroad data model.
Pedestrian and cycle path	8	Pedestrian and cycle paths are mainly used by pedestrians and bicycles and, in some cases, mopeds.
	0 / null	No data

4.1.3 *Direction of traffic flow*

Definition

The direction of traffic flow is determined in relation to the direction of digitization of a road link.

Pedestrian and cycle paths may also be described as one-way if the traffic is only allowed in one direction.

Coverage

Data applies to all road links.

Abbreviation in the Road Link table

[AJOSUUNTA](#)

DIRECTION OF TRAFFIC FLOW	
Direction of traffic flow	Code value
Traffic is permitted in both directions	2
Traffic is permitted against the direction of digitization	3
Traffic is permitted in the direction of digitization	4

4.1.4 Road link type

Definition

The road link type describes the physical or traffic attribute data of a road link.

Coverage

Data applies to all road links.

Abbreviation in the Road Link table

[LINKKITYYP](#)

ROAD LINK TYPE	
Road link type	Code value
Part of a motorway	1
Part of a multiple carriageway, which is not a motorway	2
Part of single carriageway	3
Part of a semi-motorway	4
Part of a roundabout	5
Slip road	6
Rest area	7
Pedestrian or cycle path	8
Part of a pedestrian zone, e.g. a pedestrian street or footpath	9
Part of a service or emergency road	10
Enclosed traffic area	11
Vehicle track, roads accessible by off-road vehicles	12
Service access point on a motorway	13
Route for special deliveries without a locked barrier structure	14
Route for special deliveries with a locked barrier structure	15
Ferry/cable ferry	21
	0 / null (no data)

4.1.5 Bridge, underpass or tunnel

Definition

Road link, which is a bridge, underpass or tunnel. The other one of the centre line geometries crossing each other on different levels has a definition underpass while at the same point the other link gets the definition bridge (although in reality the lowest/upper road link is at the ground level).

The bridges that cross each other are classified according to their level in the following way: the first bridge from the ground level gets the value 1, the second one gets the value 2, etc. The levels below the ground are marked with values -2 and -3 in the way that the -2 level is closer to the ground level.

Coverage

Data applies to all road links.

Abbreviation in the Road Link table

[SILTA ALIK](#)

BRIDGE, UNDERPASS OR TUNNEL	
Bridge, underpass or tunnel	Code value
Tunnel	-11
Underground level	-3
Underground level	-2
Underpass	-1
At the Ground level	0
Bridge, level 1	1
Bridge, level 2	2
Bridge, level 3	3
Bridge, level 4	4

4.1.6 Address data

Definition

A road link, which has a road number, road part number, carriageway information and start and end distance from the beginning of the road part.

Åland has the same road number

The road link address data include street names in Finnish, Swedish and Sami (if present), the first house on the right and left, the last house on the right and left, and the municipality code.

If the road link does not have address numbers, the field value 0 / null (No data) (in the Digiroad releases) is used. If a link is located in the border of two municipalities the municipality code refers to the municipality in which link is mostly located in. The municipality codes consist of one to three digits, no initial zeros are added (eg. Helsinki 91).

Abbreviation in the Road Link table

[TIENIMI_SU](#);

[TIENIMI_RU](#);

[TIENIMI_SA](#);

[ENS_TALO_V](#);

[ENS_TALO_O](#)

[VIIM_TAL_V](#)

[VIIM_TAL_O](#)

[KUNTAKOODI](#)

4.1.7 Road address data

Definition

Road link including a road number and the number of the part of the road, carriage way and start and end distance for the road link (from the beginning of the road part).

Since Åland and the mainland share the same road numbering space, the road links in Åland have the same road numbers as in the continental Finland.

Coverage

Information applies to all state owned roads.

Abbreviation in the Road Link table

[TIENUMERO](#); [TIEOSANRO](#); [AJORATA](#); [AET](#); [LET](#)

4.1.8 Geometric accuracy

Definition

The accuracy of the horizontal position of the road link is a metric class, for example 3 metres.

Abbreviation in the Road Link table

[SIJ_TARK](#); [KOR_TARK](#)

GEOMETRIC ACCURACY	
Accuracy of the horizontal position	Code value
Not defined	0
0,5 m	500
0,8 m	800
1 m	1000
2 m	2000
3 m	3000
4 m	4000
7 m	5000
7,5 m	7500
8 m	8000
10 m	10000
12,5 m	12500
15 m	15000
20 m	20000
25 m	25000
30 m	30000
40 m	40000
80 m	80000
100 m	100000

If the vertical accuracy information for the road link is interpolated from the height model, the code is either "KM10" (traced from the 10 m resolution height model), or "KM25" (traced from the 25 m resolution height model).

VERTICAL ACCURACY	
Vertical accuracy	Code value
Not defined	1
KM 2 m	201
0,5 m	500
0,8 m	800
1 m	1000
2 m	2000
3 m	3000
4 m	4000
5 m	5000
7,5 m	7500
8 m	8000
10 m	10000
12,5 m	12500
15 m	15000
20 m	20000
25 m	25000
30 m	30000
40 m	40000
80 m	80000
100 m	100000
KM 10 m	100001
KM 25 m	250001

4.1.9 *Digitisation direction in relation to the geometry of National Land Survey of Finland*

Definition

With the assistance of this field it can be deduced, if the direction of the digitization has changed in relation to the direction of digitization mentioned in the topographic database of the National Land Survey of Finland.

Abbreviation in the Road Link table

[GEOM_FLIP](#)

DIRECTION OF TRAFFIC FLOW	
Direction of traffic flow	Code value
Direction of digitization remained the same	0
Changed direction of digitization	1

4.1.10 *Link phase*

Definition

Road link phase specifies, whether the road link is in use, under construction or planned. Link will be defined as “planned” if an investment decision has been made.

Abbreviation in the Road Link table

[LINK_TILA](#)

LINK PHASE	
Link phase	Code value
Digitisation direction remains the same	0
Under construction	1
Planned	3

4.1.11 *Source of the link geometry*

Definition

Source of the road link specifies, whether the link geometry derives from the National Land Survey or some other data source. Other sources remain unspecified at least at this stage. If a need for a more detailed information concerning the sources arises in the future, this classification can be specified.

Abbreviation in the Road Link table

[GEOM_LAHDE](#)

SOURCE OF LINK GEOMETRY	
Geometry source	Code value
National Land Survey	1
Other, not specified	2

4.1.12 *Other attribute data of the road link*

The other attribute data of the road link include:

- The date of the last edition [MUOKKAUSPV](#)
- Link ID
- [LINK_MML_ID](#)
- The M value of the start and the end point of the link [ALKU_PAALU](#) ja [LOPP_PAALU](#)
- The attribute data also includes road classification according to the topographic database by the National Land Survey ([MTK_TIE_LK](#)). The information included in the classification is described more specifically in National Land Survey's website (www.maanmittauslaitos.fi).

4.2 Restricted manoeuvre

Definition

Restricted manoeuvre indicates prohibited or blocked manoeuvres.

Restricted manoeuvre data refers to the relation between road links. Restricted manoeuvre consists at least of the related start and end links (U-turns can consist of up to four links), period of validity, exceptions and additional data. Exceptions indicate the vehicles to which the restriction is not applied.

Manoeuvre data is carriageway specific, not lane specific. Restricted manoeuvre can exist between road links only if turning to another road link is forbidden from each lane.

In Digiroad, no such restricted manoeuvre is maintained that is forbidden by the Road Traffic Act. These include, for example turning to one-way road link against the direction of the traffic flow or turning to pedestrian or cycle path.

Coverage

Information applies to roads, streets and private roads.

Link to the Restricted manoeuvre table

[Restricted manoeuvre](#)

RESTRICTED MANOEUVRE	
Exception to the restricted manoeuvre	Code value
Truck	4
Bus	5
Van	6
Passenger car	7
Taxi	8
Motorcycle	9
Moped	10
Articulated vehicle	13
Tractor or farm vehicle	14
Car with trailer / recreational vehicle	15
Military vehicle	19
Driving in service purposes	21
Driving to a lot	22
Snow mobile	27

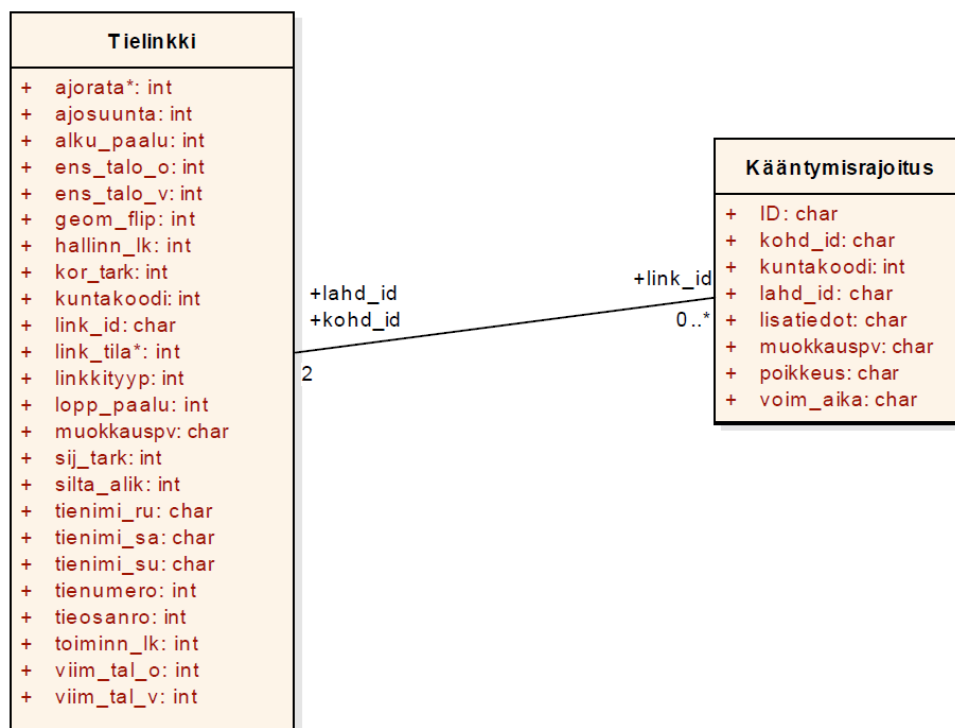

Restricted manoeuvre can be joined to road links according to the source link ID information and the object link ID information.

Tielinkki – Road link

Kääntymisrajoitus – Restricted manoeuvre

lahd_id – Source link ID

kohd_id – Object link ID

4.3 Point attribute data

Point attribute data refer to linear referencing attribute data that have only one M value which is the distance from the start of the link. All point attribute data objects have at least the following data:

POINT ATTRIBUTE DATA		
Attribute data	Data type	Description
ID*	Numerical	The ID identifying the object
Link ID	Numerical	The link ID of the link where the object is located.
Distance from the start of the link	Numerical	The position of the object on a road link measured from the start.
Last edited	Character string	Time last edited or added to the system.
Municipality code	Code value	Municipality code of the object.

*) For the bus stops, the national ID is used.

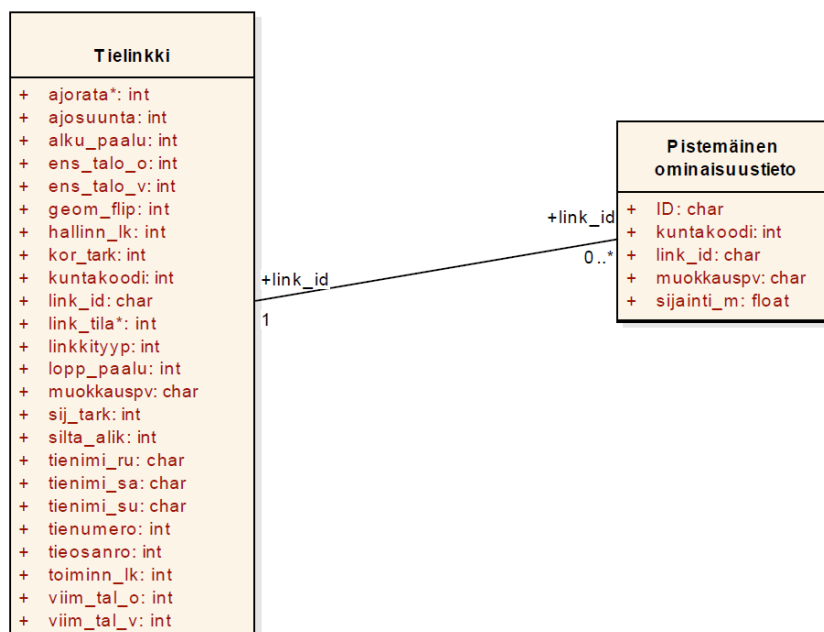

Figure: Point attribute data can be joined to the road links by linear referencing, according to the link ID attribute data and M values.

Tielinkki – Road link

Pistemäinen ominaisuustieto – Point attribute data

4.3.1 Public transport stop

Definition

A stop used by public transport.

The position of the public transport stop either refers to the position in the material provided or a position assigned to the stop in the user interface. In the interface, the position of the stop is generated by linear referencing. In this case, the road link of the stop and the M value determining its position on the road link are known. In addition, the stop is assigned by its coordinates (x, y) in the interface.

The position given by the data provider is indicated in the fields X (east coordinate), Y (north coordinate) and Z (height). These coordinates are assigned in the user interface and do not necessarily match with the linearly referenced positions.

For public transport stop facility data and other attribute data, please see Appendix 2.

Coverage

A public transport stop can be located on any road link with the exception of pedestrian and cycle paths, ferries and cable ferries.

Link to the Public transport stop table

[Public transport stop](#)

PUBLIC TRANSPORT STOP			
Attribute data	Data type	Description	Code values
Coordinate X (easti coordinate)	Numerical	X coordinate of the stop in the Digiroad database. Calculated using the road link and M value.	
Coordinate Y (north coordinate)	Numerical	Y coordinate of the stop in the Digiroad database. Calculated using the road link and M value.	
Link ID	Numerical	The Link-ID of the road link where the stop is located*	
M value	Numerical	Stop position on the road link*	
Validity direction	Code value	Stop validity direction in relation to the direction of digitisation of a road link*	2 In the direction of digitisation 3 Against the direction of digitisation
Last edited	Character string	The date the object was last modified.	
National ID	Numerical	Nationally unique identifier for the stop.	
Name in Finnish	Character string	Name of the stop in Finnish.	
Name in Swedish	Character string	Name of the stop in Swedish.	
Data administrator	Code value	Authority administering the data in Digiroad.	1 Municipality 2 Centre for Economic Development, Transport and the Environment (ELY Centre) 3 Helsinki Regional Transport 99 Not known
Administrator identifier	Character string	The unique identifier assigned to the stop by the administrator in their own system.	
Livi identifier	Character string	The stop Livi identifier that corresponds to the identifier in the road register. Only applies to stops on the roads.	
Traveller identifier	Character string	The stop identifier physically displayed at the public transport stop.	

Ground coordinate X (east coordinate)	Character string	The calculated X coordinate of the stop's location. Ground coordinates are provided by the data administrator and may not correspond to those given in the application.	
Ground coordinate Y (north coordinate)	Character string	The calculated Y coordinate of the stop's location. Ground coordinates are provided by the data administrator and may not correspond to those given in the application.	
Ground coordinate Z	Character string	The calculated Z coordinate of the stop's location. Ground coordinates are provided by the data administrator and may not correspond to those given in the application.	
Direction of travel	Character string	Free description of the direction of the stop.	
Traffic bearing	Numerical	Degree between 0 and 360. Describes the stop validity direction.	
Valid from date	Time stamp	Date when the stop is first used.	
Valid to date	Time stamp	Date when the stop is used for the last time.	
Stop type	Code value	The stop type indicates the type of traffic served by the stop. A stop may be assigned more than one type.	<ul style="list-style-type: none"> 1 Tram 2 Local transport 3 Long-distance transport 4 Express bus 5 Virtual stop 6 Terminal 99 No data
Disconnected from geometry**	Code value	The geometry of the road link where the stop is located has changed considerably, disconnecting the stop from the geometry.	<ul style="list-style-type: none"> 1 Connected to geometry 2 Disconnected from the geometry

**) If the stop is disconnected from geometry, its Link-ID, M value and validity direction are null.*

****) The expired stops anymore are not updated to the link geometry if the geometry is changed.*

4.3.2 Barrier

Definition

Barriers are blocked passages or traffic barrier gates which can be opened. Blocked passage refers to a physical barrier on the road and street network that prevents passing through. For example, the connection of the streets may be blocked with stones, ditch or a traffic barrier gate which cannot be opened.

A traffic barrier gate which can be opened is a point in a central line geometry which is locked, but can be opened.

Coverage

Information applies to streets and private roads.

Link to the Barrier table

[Barrier](#)

BARRIER	
Barrier type	Code value
Blocked passage	1
Traffic barrier gate which can be opened	2

4.3.3 *Traffic light*

Definition

Intersection traffic light control is marked as a point segment at the distance of 5 meters from the intersection. It applies on all the links that have direction of travel towards the intersection.

A traffic light that is between intersections is described as a point e.g. beside a pedestrian crossing guided by traffic lights in the case that no intersecting geometry exists.

Coverage

Information applies to roads and streets.

Link to the Traffic light table

[Traffic light](#)

4.3.4 *Pedestrian crossing*

Definition

A pedestrian crossing marked with a traffic sign and road markings.

Coverage

Information applies to streets.

Link to the Pedestrian crossing table

[Pedestrian crossing](#)

4.3.5 Directional traffic sign

Definition

Directional traffic sign and its information are the signposts which are situated on or directing to motorways or semi-motorways. Typically directional sign is located at a junction or just before it. There may be several directions (pieces of information on a directional sign) on a directional traffic sign.



Image shows four directions, i.e. four pieces of information, on a directional traffic sign (in a directional traffic sign segment).

Directional traffic sign information contains the following data, separated by a semicolon:
PLACE NAMES;COLOUR;LOCATION

Within the fields, the information is separated by a colon, for example:
"HELSINKI:HELSINGFORS;1;500"

More detailed description of the parts of the character string:

Place names: Names of places written as in the directional traffic sign (all CAPITAL letters).

Background colour:

- 1 no data
- 2 green (motorway or semi-motorway)
- 3 blue (road)
- 4 white (local, e.g. a town district)

Location

Distance of the directional traffic sign from the junction in metres.

Coverage

Information applies to streets, roads (1-299), and some private roads. Information is not particularly comprehensive and its quality may vary according to the area.

Link to the Directional traffic sign table

[Directional traffic sign](#)

DIRECTIONAL TRAFFIC SIGN			
Attribute data	Data type	Description	Code values
Validity direction	Code value	Direction of travel in relation to the direction of the digitation on link.	2 In the direction of the digitisation 3 Against the direction of the digitisation
Bearing	Numerical	Degree	
Text	Character string	List of content	

4.3.6 *Railway crossing*

Definition

Railway crossing includes:

- a name
- type of safety device

Coverage

Information applies to roads, streets and some private roads.

Link to the Railway crossing table

[Railway crossing](#)

RAILWAY CROSSING	
Type of safety device	Code value
Railway not in use	1
No safety device	2
Only light and/or sound signal	3
Half barrier and possible light and/or sound signal	4
Full barrier and possible light and/or sound signal	5

4.3.7 *Forest road turnaround point (pilot)*

Definition

A forest road turnaround point which is meant for a timber truck (a truck with timber cargo).

Coverage

Forest road turnaround point data is pilot data produced from Forest Centre data.

Link to the Forest road turnaround point

[Forest road turnaround point](#)

4.4 Line attribute data

Line attribute data refers to linear referencing attribute data in which the start and end M values are not the same. All line attribute data objects have at least the following data:

LINE ATTRIBUTE DATA		
Attribute data	Data type	Description
ID	Numerical	The ID identifying the object
Link ID	Numerical	The Link ID of the link where the object is located.
Start M value	Numerical	The distance of the start point from the start of the link.
End M value	Numerical	The distance of the end point from the start of the link.
Last edited	Character string	The date the object was last modified.
Municipality code	Code value	Municipality code of the object.

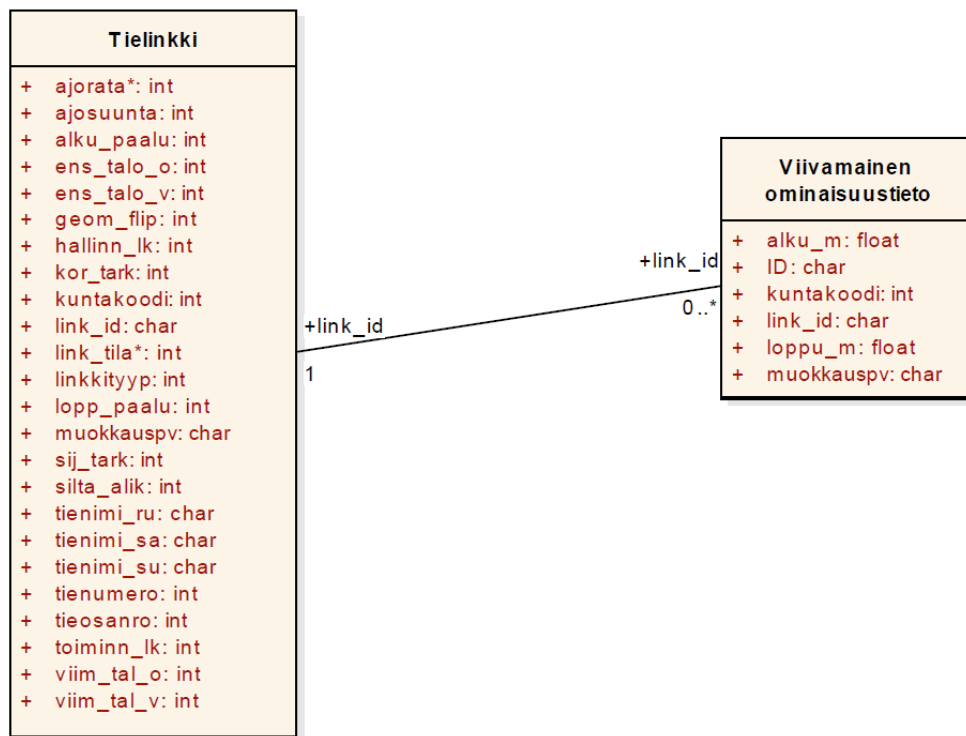

Image: Line attribute data can be joined to the road links by linear referencing, according to the link ID attribute data and the M values.

Tielinkki – Road link

Viivamainen ominaisuustieto – Line attribute data

4.4.1 Speed limit

Definition

The maximum vehicle speed assigned to a route.

Values

Arvo (value) field indicates the speed limit value (km/h). Speed limit 90 km/h is only used in Åland.

Coverage

Speed limit applies to all road links excluding pedestrian and cycle paths and vehicle tracks. If the administrator has not updated the road link speed limit, an empty speed limit with null value is generated for the link. The null speed limit does not have an ID.

Link to the Speed limit table

[Speed limit](#)

SPEED LIMIT			
Attribute data	Data type	Description	Code values
Validity direction	Code value	Validity direction in relation to the direction of digitisation of a road link.	1 Both directions 2 In the direction of digitisation 3 Against the direction of digitisation

4.4.2 *Maximum allowed ... x 7*

Maximum allowed restrictions are:

- Maximum weight allowed for a vehicle
- Maximum weight allowed for an articulated vehicle
- Maximum weight per axle allowed for a vehicle
- Maximum weight per tandem-axle allowed for a vehicle
- Maximum height allowed for a vehicle
- Maximum length allowed for a vehicle or articulated vehicle
- Maximum width allowed for a vehicle

Definition

The 'maximum allowed...' attribute data are line attribute data that cover all the area, where the restriction is valid. The weight restrictions are indicated with an accuracy of 100 kilograms and the height, length and width restrictions as centimetres. For roads, height restrictions below 440 cm are indicated. The unit of weight restrictions is kg and the unit of height, length and width restrictions is cm.

Values

Arvo (value) field indicates the value of the restriction (kg or cm).

Coverage

Information applies to roads, streets and some private roads. The information is to be saved for all the area, where the restriction is valid.

Link to the Maximum allowed... table

[Maximum weight allowed for a vehicle](#)

[Maximum weight allowed for an articulated vehicle](#)

[Maximum weight per axle allowed for a vehicle](#)

[Maximum weight per tandem-axle allowed for a vehicle](#)

[Maximum height allowed for a vehicle](#)

[Maximum length allowed for a vehicle or articulated vehicle](#)

[Maximum width allowed for a vehicle](#)

4.4.3 *Lit road*

Definition

The road has lighting. Lit road is line attribute data which may apply to the whole link or only to a part of it.

Coverage

Information applies mainly to roads and streets.

Link to Lit road table

[Lit road](#)

4.4.4 *Paved road*

Definition

All pavement types are classified as pavements. There is no pavement segment on the part of road network covered with gravel. Nearly always the pavement information covers the whole link. The data source for all road links is the topographic database of The National Land Survey of Finland.

Coverage

Information applies to all route types.

Link to Paved road table

[Paved road](#)

4.4.5 *Road affected by thawing*

Definition

Road affected by thawing is the part of the traffic network that tends to suffer from thawings.

Coverage

Information applies mainly to main roads.

Link to Road affected by thawing table

[Road thawing](#)

4.4.6 *Width*

Definition

Road width is the width of the part of the carriageway meant for vehicle traffic. On paved roads the carriageway is often separated from the shoulders with a white border line. If a border line doesn't exist, the width equals the width of the paving. On gravel roads the width equals the width of the whole road, since gravel roads don't have shoulders.

Values

Arvo (value) field indicates the value of the width (cm).

Coverage

Information applies to roads, streets and private roads.

Link to Width table

[Width](#)

4.4.7 *Traffic volume*

Definition

Traffic volume is the average number of vehicles passing per day. If the road that consists of one carriageway is split into two carriageways, both carriageways get the same traffic volume value that existed for the road before the splitting.

Values

Arvo (value) field indicates the traffic volume (vehicles per day).

Coverage

Information applies to roads and partially to the road network. From publication 3/2017 the information is produced directly from FTA road register. The inventory information is updated once a year and it is based on measurements made during the previous fall.

Link to Traffic volume table

[Traffic volume](#)

4.4.8 *Vehicle specific restriction*

Definition

A part of the road network where driving with a certain vehicle type(s) is prohibited by traffic signs. Validity period can be given by a vehicle specific restriction. The vehicles that are not covered by the restriction can be added as exceptions to the vehicle, motor vehicle and passage through restrictions.

In Digiroad, the vehicle specific restrictions which the Road Traffic Act imposes or which are indicated by the selection of the road link type are not maintained on motorways and other corresponding road types (including semi-motorway, pedestrian and cycle path).

If one position includes several prohibited vehicle types, objects that overlap by geometry are formed to the R and K releases of Digiroad. These objects have the same restriction ID, position information and last edited time data.

Coverage

Information applies mainly to roads and streets.

Link to Vehicle specific restriction table

[Vehicle specific restriction](#)

VEHICLE SPECIFIC RESTRICTION			
Attribute data	Data type	Description	Code values
Validity direction	Code value	Validity direction in relation to the direction of digitisation of a road link.	1 Both directions 2 In the direction of digitisation 3 Against the direction of digitisation
Type of prohibited vehicle	Code value	Type of prohibited vehicle	2 Motor vehicle 3 Vehicle 4 Truck 5 Bus 6 Delivery vehicle 7 Passenger car 8 Taxi 9 Motorcycle 10 Moped 11 Cycle 12 Pedestrian 13 Articulated vehicle 14 Tractor or farm vehicle 15 Car with trailer / recreational vehicle 19 Military vehicle 21 Driving in service purposes 22 Driving to a lot 23 Passage through 26 Horse riding 27 Snow mobile 28 Special transport
Validity period	Character string	Validity period of the restriction, time domain	
Exceptions	Code value	Vehicle types not covered by the restriction. Exceptions	Same code values as in the type of prohibited vehicle.

can apply to
restrictions of vehicle,
motor vehicle and
passage through.

4.4.9 *Restriction for the transportation of dangerous goods (VAK)*

Definition

A part of the road network where the transportation of dangerous goods (VAK) is prohibited.

The value of VAK restriction can be A-VAK or B-VAK which is shown in a plate of the restriction sign.

If the restriction includes both A-VAK and B-VAK, they will be formed as geometrically overlapping objects to the R and K releases of Digiroad. A-VAK and B-VAK are never valid simultaneously, so the overlapping objects have always a period of validity for the restriction. These objects have the same restriction ID, position information and last edited time data.

Coverage

Information applies to roads and streets.

Link to Restriction for the transportation of dangerous goods table

[Restriction for the transportation of dangerous goods](#)

RESTRICTION FOR THE TRANSPORTATION OF DANGEROUS GOODS (VAK)		
Attribute data	Data type	Description
Validity direction	Code value	Validity direction in relation to the direction of digitisation of a road link. 1 Both directions 2 In the direction of digitisation 3 Against the direction of digitisation
Type of prohibited vehicle	Code value	24 A-VAK 25 B-VAK
Validity period	Character string	Validity period of the restriction, time domain

4.4.10 *Number of lanes*

Definition

Information on the number of lanes is given according to the direction when there is more than one lane in a particular direction on one carriageway roads, and more than two lanes on two carriageway roads. Diverging lanes on the junctions are not included.

In the following cases, there is no information on the number of lanes in Digiroad:

- one-way road with one carriageway: 1 lane (one lane in the direction of the traffic flow)
- two-way road with one carriageway: 1+1 lanes (one lane in the direction of the traffic flow)
- two-way road with two carriageways: 2+2 lanes (two lanes in the direction of the traffic flow)

Example 1: In a one carriageway road at the point where there is a passing/fast lane in the direction of the digitisation, the validity direction is 2 and the number of lanes 2.

Example 2: In a one carriageway road at the point where there are passing/fast lanes to both directions, the validity direction is 1 and the number of lanes 2.

Coverage

Information applies to roads and streets.

Link to Number of lanes table

[Number of lanes](#)

NUMBER OF LANES		
Attribute data	Data type	Description
Validity direction	Code value	Validity direction in relation to the direction of digitisation of a road link. 1 Both directions 2 In the direction of the digitisation 3 Against the direction of digitisation
Number of lanes	Numerical	Number of lanes according to the direction (>1)

4.4.11 *Public transport lane*

Definition

A road with a public transport lane.

Coverage

Information applies to roads and streets.

Link to Public transport lane table

[Public transport lane](#)

PUBLIC TRANSPORT LANE		
Attribute data	Data type	Description

Validity direction	Code value	Validity direction in relation to the direction of digitisation of a road link. 1 Both directions 2 In the direction of the digitisation 3 Against the direction of digitisation
--------------------	------------	---

4.4.12 *E-road number*

Definition

E-road number are of the form E+<number>. One road can have many E-road numbers.

If a road has two or more E-road numbers, they are listed in R and K releases of Digiroad and separated from each other by a comma.

Coverage

Information applies to roads and in few cities also to streets.

Link to E-Road number table

[E-road number](#)

4.4.13 *Exit number*

Definition

Exit numbers are numbers given to ramps on motorways or semi-motorways. Exit numbers can consist of both a number and a letter, for example exit numbers 9A and 9B in Vantaankoski.

If one road has two or more exit numbers, they are listed in R and K releases of Digiroad and separated from each other by a comma.

Coverage

Information applies to the motorway and semi-motorway ramps (on the roads).

Link to Exit number table

[Exit number](#)

4.4.14 *Winter speed limit*

Definition

Speed limit during winter data is based on decisions made by local road authorities (ELY) in autumn 2016. Speed limits during winter is no longer applied on the road segments (in the intersections) where regular speed limit is lower than speed limit during winter.

Values

Arvo (value) field indicates the value of the winter speed limit (km/h).

Coverage

Information applies to roads.

Link to Winter speed limit

[Winter speed limit](#)

4.5 Other features

4.5.1 Service

Definition

Service means the kind of service that helps and supports the users of traffic network, e.g. a parking building or bus station. Service has a point geometry (service point) which is located at the point where the service exist (in the middle/centre point of a building or property), not on a road link. One service point may have many services.

If one service point has many services, objects that overlap the geometry are formed to the shapefiles of the R and K releases of Digiroad. These overlapping objects have the same service point ID, position information and last edited time.

Coverage

The coverage of data varies according to the service.

Link to Service table

[Service](#)

SERVICE		
Attribute data	Data type	Description
Service point ID	Numerical	The ID identifying the service point
Service ID	Numerical	The ID identifying the service
Service type	Code value	The type of the service
Specifier of the rest area	Code value	The type of the rest area on rest areas or lay-bys, parking areas and bus and truck parking areas
Type of railway station	Code value	

Name of service	Character string	
Number of parking spaces	Numerical	Number of parking spaces on parking areas and houses
Additional information of the service	Character string	

TYPE OF SERVICE		
Type of service	Code value	Description
Customs	4	
Frontier crossing	5	
Rest area (or lay-by)	6	Rest area, petrol station, kiosk, cafeteria, restaurant or accommodation services.
Airport	8	An airport which accommodates either cargo or passenger traffic of a commercial or private nature.
Ferry terminal	9	The access point or check-in area for a ferry company.
Taxi stand	10	
Railway station	11	
Parking lot	12	Parking lot which has at least 40–50 public parking spaces. There may be a charge for parking but there may not be other restrictions (e.g. parking only allowed for customers of a particular store). In addition, parking lot object can also include more accurate information about facilities.
Car shipping terminal	13	A location where cars may be loaded onto trains or ferries.
Coach and lorry parking (area / lot)	14	
Parking house/building	15	Parking house/building which has at least 40–50 public parking spaces. There may be a charge for parking but there may not be other restrictions (e.g. parking only allowed for customers of a particular store).
Bus station	16	

TYPE OF REST AREA		
Type of rest area	Code value	Description
Rest area, comprehensive facilities	1	Comprehensive facilities include other facilities and services in addition to the basic ones
Rest area, basic facilities	2	Basic facilities include the following facilities or services: - parking area - waste container - toilets - table and bench

Private service area	3	Privately run service area has e.g. a petrol station, kiosk, cafeteria, restaurant or accommodation services.
No data	4	

TYPE OF RAILWAY STATION	
Type of railway station	Code value
Important railway station	1
Less important railway station	2
Underground/metro station	3

Appendices

Appendix 1. [Description of data content - field names, data types and code values](#)

Appendix 2. [Public transport stop facility data and other attribute data](#)

Appendix 3. [Primary data sources by data objects](#)

Appendix 4. [Route type](#)

Appendix 5. [Time Domain character string](#)

Appendix 1. Description of data content - field names, data types and code values

Road link

Line

Description	Field (shape)/ Element (WFS)	Data type (shape)	Additional information
Link breakpoints	shape/ points	geometry (polylineZm)	X and Y coordinates: ETRS-TM35FIN Z coordinate: N60 M value: metre (X,Y level)
Link ID	LINK_ID	text, 20	
ID (by the National Land Survey)*	LINK_MML_ID	text, 20	
Administrative class	HALLINN_LK	integer	code value
Functional class	TOIMINN_LK	integer	code value
Direction of traffic flow	AJOSUUNTA	integer	code value
Link type	LINKKITYYP	integer	code value
Bridge, underpass or tunnel	SILTA_ALIK	integer	code value
Link phase	LINK_TILA	integer	code value (to be published later)
Name of road or street in Finnish	TIENIMI_SU	text, 200	
Name of road or street in Swedish	TIENIMI_RU	text, 200	
Name of road or street in Sami	TIENIMI_SA	text, 200	
Address first house on the left	ENS_TALO_V	integer	
Address first house on the right	ENS_TALO_O	integer	
Address last house on the left	VIIM_TAL_V	integer	
Address last house on the right	VIIM_TAL_O	integer	
Municipality code	KUNTAKOODI	integer	
Road number	TIENUMERO	integer	

Number of the part of a road	TIEOSANRO	integer	
Carriageway	AJORATA	integer	code value
Start measure from the beginning of the road part	AET	integer	
End measure from the beginning of road part	LET	integer	
Horizontal accuracy	SIJ_TARK	integer	code value
Vertical accuracy	KOR_TARK	integer	code value
Digitisation direction in relation to the geometry of National Land Survey of Finland	GEOM_FLIP	integer	code value
Start M value	ALKU_PAALU	double	
End M value	LOPP_PAALU	double	
Last edited	MUOKKAUSPV	text, 20	time stamp "12.06.2014 13:29:17"
Source geometry	GEOM_LAHDE	integer	code value
Road classification according to the topographic database (National Land Survey)	MTK_TIE_LK	integer	code value, explanations can be found in the description by the National Land Survey

* If the link does not have a MML-ID, this means that its' source is some other than the National Land Survey.

Name	Code value	Description
Administrative class	1	Road owned by the state
	2	Road owned by a municipality
	3	Road owned privately, e.g. by a road association
	99	No data
Functional class	1	Class I main road or regional main street
	2	Class II main road or regional main street
	3	Regional road or local main street
	4	Connecting road or collector street
	5	Feeder street or class I private road
	6	Class II private road
	7	Vehicle track
	8	Pedestrian and cycle path

	0 / null	No data
Direction of traffic flow	2	Traffic is permitted in both directions
	3	Traffic is permitted against the direction of digitisation
	4	Traffic is permitted in the direction of digitisation
Link type	1	Part of a motorway
	2	Part of a multiple carriageway, which is not a motorway
	3	Part of single carriageway
	4	Part of a semi-motorway
	5	Part of a roundabout
	6	Slip road
	7	Rest area
	8	Pedestrian or cycle path
	9	Part of a pedestrian zone, e.g. a pedestrian street or footpath
	10	Part of a service or emergency road
	11	Enclosed traffic area
	12	Vehicle track, roads accessible by off-road vehicles
	13	Service access point on a motorway
	14	Route for special deliveries without a locked barriere structure
	15	Route for special deliveries with a locked barriere structure
	21	Ferry/cable ferry
	0 / null	No data
Bridge, underpass or tunnel	-11	Tunnel
	-3	Underground
	-2	Underground
	-1	Underpass
	0	At ground level
	1	Bridge, level 1
	2	Bridge, level 2
	3	Bridge, level 3
	4	Bridge, level 4
Link phase	1	In use

	2	Under construction
	3	Planned
	9	Removed
Carriageway	1	First carriageway on the right in the direction of the road number
	2	Second carriageway on the right in the direction of the road number
	0	Single carriageway road
Accuracy for the geometries	0	Not defined
	500	0,5 m
	800	0,8 m
	1000	1 m
	2000	2 m
	3000	3 m
	4000	4 m
	5000	7 m
	7500	7,5 m
	8000	8 m
	10000	10 m
	12500	12,5 m
	15000	15 m
	20000	20 m
	25000	25 m
	30000	30 m
	40000	40 m
	80000	80 m
	100000	100 m
Vertical accuracy	1	Not defined
	201	KM (EM) (traced from the 2 m resolution model)
	500	0,5 m
	800	0,8 m
	1000	1 m
	2000	2 m
	3000	3 m

Digiroad

	4000	4 m
	5000	5 m
	7500	7,5 m
	8000	8 m
	10000	10 m
	12500	12,5 m
	15000	15 m
	20000	20 m
	25000	25 m
	30000	30 m
	40000	40 m
	80000	80 m
	100000	100 m
	100001	KM (EM) 10 m (traced from the 10 m resolution model)
	250001	KM 25 m (traced from the 25 m resolution model)
Digitisation direction in relation with the geometry of National Land Survey of Finland	0	Direction of digitization remained the same
	1	Changed direction of digitisation
Source geometry	1	National Land Survey
	2	other, not specified

Restricted manoeuvre

Relationship between the links

Restricted manoeuvre information is complementary data for road links. Its utilization requires that the road link material/data is in use. For visualization, the geometry for the restricted manoeuvre has been formed in the release from the geometry of the source and object links.

Description	Field (shape)/ Element (WFS)	Data type (shape)	Additional information
ID	ID	text, 20	
Position	shape/ points	geometry (polylineZ)	ETRS-TM35FIN, formed from the source and object link geometry
Source link ID	LAHD_ID	text, 20	
Object link ID	KOHD_ID	text, 20	
Vehicles not covered by restricted manoeuvre	POIKKEUS	text, 40	comma-separated list of vehicle types
Validity period	VOIM_AIKA	text, 200	time domain
Additional information	LISATIEDOT	text, 200	
Last edited	MUOKKAUSPV	text, 50	time stamp "12.6.2014 13:29:17"
Municipality code	KUNTAKOODI	integer	

Name	Code value	Description
Vehicle type	4	Truck
	5	Bus
	6	Van
	7	Passenger car
	8	Taxi
	9	Motorcycle
	10	Moped

	13	Articulated vehicle
	14	Tractor or farm vehicle
	15	Car with trailer/ recreational vehicle
	19	Military vehicle
	21	Driving in service purposes
	22	Driving to a lot
	27	Snow mobile

Public transport stop

Point

Description	Field (shape)/ Element (WFS)	Data type (shape)	Additional information
National ID	VALTAK_ID	integer	
Position	shape/point	geometry (pointZ)	ETRS-TM35FIN
Coordinate X	KOORD_X	double	ETRS-TM35FIN
Coordinate Y	KOORD_Y	double	ETRS-TM35FIN
Link ID	LINK_ID	text, 20	
Sijainti linkillä	SIJAINTI_M	double	M value: metre (x, y level)
Validity direction	VAIK_SUUNT	integer	code value
Name in Finnish	NIMI_SU	text, 200	
Name in Swedish	NIMI_RU	text, 200	
Data administrator	YLLAPITAJA	integer	code value
Administrator identifier	YLLAP_TUNN	text, 50	
Livi identifier	LIVI_TUNN	text, 50	
Traveller identifier	MATK_TUNN	text, 50	
Ground coordinate X	MAAST_X	text, 50	

Ground coordinate Y	MAAST_Y	text, 50	
Ground coordinate Z	MAAST_Z	text, 50	
Direction of travel	LIIK_SUUNTA	text, 200	
Traffic bearing	L_SUUNTIMA	integer	degree 0-360
Valid from date	ENS_VO_PV	text, 50	time stamp "12.06.2014"
Valid to date	VIIM_VO_PV	text, 50	time stamp "12.06.2014"
Stop type	PYS_TYYPPI	text, 20	comma-separated list of types, no square brackets
Timetable	AIKATAULU	integer	code value
Shelter	KATOS	integer	code value
Bench	PENKKI	integer	code value
Advertising shelter	MAINOSKAT	integer	code value
Cycle rack	PYORATELIN	integer	code value
Electronic timetable board	S_AIKATAUL	integer	code value
Lighting	VALAISTUS	integer	code value
Accessibility to persons with reduced mobility	ESTETTOMYY	text, 200	
Possibility to escort by car	SAATTOMAHD	integer	code value
Number of park-and-ride places	LIIT_LKM	text, 200	
Additional information on park-and-ride facilities	LIIT_LISAT	text, 200	
Stop owner	PYS_OMIST	text, 200	
Feedback address	PALAUTE_OS	text, 200	
Additional information	LISATIEDOT	text, 200	
Disconnected from geometry	IRTI_GEOM	integer	code value
Last edited	MUOKKAUSPV	text, 50	time stamp "12.06.2014 13:29:17"
Municipality code	KUNTAKOODI	integer	

Name	Code value	Description
Data administrator	1	Municipality
	2	Centre for Economic Development, Transport and the Environment
	3	Helsinki Regional Transport

	99	Unknown
Validity direction	2	In the direction of digitisation
	3	Against the direction of digitisation
Stop type	1	Tram
	2	Local transport
	3	Long-distance transport
	4	Express
	5	Virtual stop
	6	Terminal
Disconnected from geometry	99	No data
	1	Connected to geometry
Timetable	2	Disconnected from geometry
	1	No
	2	Yes
	99	No data
Shelter	1	No
	2	Yes
Advertising shelter	99	No data
	1	No
	2	Yes
	99	No data
Bench	1	No
	2	Yes
Cycle rack	99	No data
	1	No
	2	Yes
	99	No data
Electronic timetable board	1	No
	2	Yes
Lighting	99	No data
	1	No
	2	Yes

	99	No data
Possibility to escort by car	1	No
	2	Yes
	99	No data

Barrier

Point

Description	Field (shape)/ Element (WFS)	Data type (shape)	Additional information
ID	ID	text, 20	
Position	shape/ point	geometry (pointZ)	ETRS-TM35FIN
Link ID	LINK_ID	text, 20	
Distance from the start of the link	SIJAINTI_M	double	
Barrier type	EST_TYYPPI	integer	code value
Last edited	MUOKKAUSPV	text, 50	time stamp "12.06.2014 13:29:17"
Municipality code	KUNTAKOODI	integer	

Name	Code value	Description
Barrier type	1	Blocked passage
	2	Traffic barrier gate which can be opened

Traffic light

Point

Description	Field (shape)/ Element (WFS)	Data type (shape)	Additional information
ID	ID	text, 20	
Position	shape/ point	geometry (pointZ)	ETRS-TM35FIN
Link ID	LINK_ID	text, 20	
Distance from the start of the link	SIJAINTI_M	double	
Last edited	MUOKKAUSPV	text, 50	time stamp "12.06.2014 13:29:17"
Municipality code	KUNTAKOODI	integer	

Pedestrian crossing

Point

Description	Field (shape)/ Element (WFS)	Data type (shape)	Additional information
ID	ID	text, 20	
Position	shape/ point	geometry (pointZ)	ETRS-TM35FIN
Link ID	LINK_ID	text, 20	
Distance from the start of the link	SIJAINTI_M	double	
Last edited	MUOKKAUSPV	text, 50	time stamp "12.06.2014 13:29:17"
Municipality code	KUNTAKOODI	integer	

Directional traffic sign

Point

Description	Field (shape)/ Element (WFS)	Data type (shape)	Additional information
ID	ID	text, 20	
Sijainti	shape/ point	geometry (pointZ)	ETRS-TM35FIN
Link ID	LINK_ID	text, 20	
Distance from the start of the link	SIJAINTI_M	double	
Validity direction	VAIK_SUUNT	integer	code value
Bearing	SUUNTIMA	integer	degree
Text	TEKSTI	text, 200	comma-separated list of texts
Last edited	MUOKKAUSPV	text, 50	time stamp "12.06.2014 13:29:17"
Municipality code	KUNTAKOODI	integer	

Name	Code value	Selite
Validity direction	2	In the direction of digitisation
	3	Against the direction of digitisation

Railway crossing

Point

Description	Field (shape)/ Element (WFS)	Data (shape)	Additional information
ID	ID	text, 20	
Position	shape/point	geometry (pointZ)	ETRS-TM35FIN

Link ID	LINK_ID	text, 20	
Distance from the start of the link	SIJAINTI_M	double	
Name of the railway crossing	NIMI	text, 200	
Type of safety device	TURVA_VAR	Integer	code value
Last edited	MUOKKAUSPV	text, 50	time stamp "12.06.2014 13:29:17"
Municipality code	KUNTAKOODI	integer	

Name	Code value	Description
Type of safety device	1	Railway not in use
	2	No safety device
	3	Only light and/or sound signal
	4	Half barrier and possible light and/or sound signal
	5	Full barrier and possible light and/or sound signal

Forest road turnaround point (pilot)

Point

Description	Field (shape)/ Element (WFS)	Data type (shape)	Additional information
ID	ID	text, 20	formed from the administrator and administrator's ID for example 1_5877
Position	shape/point	geometry (pointZ)	ETRS-TM35FIN
Link ID	LINK_ID	text, 20	
Distance from the start of the link	SIJAINTI_M	double	
Type of turnaround point	KAANT_TYYP	integer	code value
Additional information of the turnaround point	LISATIEDOT	text, 200	

Administrator of the turnaround point	YLLAPITAJA	integer	code value
Administrator´s ID for the turnaround point	YLLAP_TUNN	text, 20	
Last edited	MUOKKAUSPV	text, 50	time stamp "12.06.2014 13:29:17"
Municipality code	KUNTAKOODI	integer	

Name	Code value	Description
Type of turnaround	1	Circle
	2	Branch shape L
	3	Branch shape I
	9	Not defined
Administrator of the turnaround point	1	Metsäkeskus Forest Centre
	2	Metsähallitus Forestry Service
	3	Tornator
	4	UPM
	5	Metsä Group
	6	Finnsilva
	7	Otso forest services

Speed limit

Line

Description	Field (shape)/ Element (WFS)	Data type (shape)	Additional information
ID	ID	text, 20	
Position	shape/ points	geometry (polylineZ)	ETRS-TM35FIN
Link ID	LINK_ID	text, 20	
Start distance from the start of the link	ALKU_M	double	
End distance from the start of the link	LOPPU_M	double	
Validity direction	VAIK_SUUNT	integer	code value
Value	ARVO	integer	code value, km/h
Last edited	MUOKKAUSPV	text, 50	time stamp "12.06.2014 13:29:17"
Municipality code	KUNTAKOODI	integer	

Name	Code value	Description
Validity direction	1	Both directions
	2	In the direction of digitisation
	3	Against the direction of digitisation
Value	20	20 km/h
	30	30 km/h
	40	40 km/h
	50	50 km/h
	60	60 km/h
	70	70 km/h
	80	80 km/h
	90	90 km/h (Åland)
	100	100 km/h

	120	120 km/h
--	-----	----------

Maximum total weight

Line

Description	Field (shape)/Element (WFS)	Data type (shape)	Additional information
ID	ID	text, 20	
Position	shape/ points	geometry (polylineZ)	ETRS-TM35FIN
Link ID	LINK_ID	text, 20	
Start distance from the start of the link	ALKU_M	double	
End distance from the start of the link	LOPPU_M	double	
Validity direction	VAIK_SUUNT	integer	code value
Value	ARVO	integer	kilogramme
Last edited	MUOKKAUSPV	text, 50	time stamp "12.06.2014 13:29:17"
Municipality code	KUNTAKOODI	integer	

Maximum total weight allowed for an articulated vehicle

Line

Description	Field (shape)/Element (WFS)	Data type (shape)	Additional information
ID	ID	text, 20	
Position	shape/ points	geometry (polylineZ)	ETRS-TM35FIN

Link ID	LINK_ID	text, 20	
Start distance from the start of the link	ALKU_M	double	
End distance from the start of the link	LOPPU_M	double	
Validity direction	VAIK_SUUNT	integer	code value
Value	ARVO	integer	kilogramme
Last edited	MUOKKAUSPV	text, 50	time stamp "12.06.2014 13:29:17"
Municipality code	KUNTAKOODI	integer	

Maximum weight per axle

Line

Description	Field (shape)/Element (WFS)	Data type (shape)	Additional information
ID	ID	text, 20	
Position	shape/points	geometry (polylineZ)	ETRS-TM35FIN
Link ID	LINK_ID	text, 20	
Start distance from the start of the link	ALKU_M	double	
End distance from the start of the link	LOPPU_M	double	
Validity direction	VAIK_SUUNT	integer	code value
Value	ARVO	integer	kilogramme
Last edited	MUOKKAUSPV	text, 50	time stamp "12.06.2014 13:29:17"
Municipality code	KUNTAKOODI	integer	

Maximum weight per tandem-axle

Line

Description	Field (shape)/ Element (WFS)	Data type (shape)	Additional information
ID	ID	text, 20	
Position	shape/points	geometry (polylineZ)	ETRS-TM35FIN
Link ID	LINK_ID	text, 20	
Start distance from the start of the link	ALKU_M	double	
End distance from the start of the link	LOPPU_M	double	
Validity direction	VAIK_SUUNT	integer	code value
Value	ARVO	integer	kilogramme
Last edited	MUOKKAUSPV	text, 50	time stamp "12.06.2014 13:29:17"
Municipality code	KUNTAKOODI	integer	

Maximum height

Line

Description	Field (shape)/ Element (WFS)	Data type (shape)	Additional information
ID	ID	text, 20	
Position	shape/points	geometry (polylineZ)	ETRS-TM35FIN
Link ID	LINK_ID	text, 20	
Start distance from the start of the link	ALKU_M	double	
End distance from the start of the link	LOPPU_M	double	
Validity direction	VAIK_SUUNT	integer	code value
Value	ARVO	integer	centimetre
Last edited	MUOKKAUSPV	text, 50	time stamp "12.06.2014 13:29:17"

Municipality code	KUNTAKOODI	integer	
--------------------------	------------	---------	--

Maximum length allowed for a vehicle or articulated vehicle

Line

Description	Field (shape)/ Element (WFS)	Data type (shape)	Additional information
ID	ID	text, 20	
Position	shape/points	geometry (polylineZ)	ETRS-TM35FIN
Link ID	LINK_ID	text, 20	
Start distance from the start of the link	ALKU_M	double	
End distance from the start of the link	LOPPU_M	double	
Validity direction	VAIK_SUUNT	integer	code value
Value	ARVO	integer	centimetre
Last edited	MUOKKAUSPV	text, 50	time stamp "12.06.2014 13:29:17"
Municipality code	KUNTAKOODI	integer	

Maximum width

Line

Description	Field (shape)/Element (WFS)	Data type (shape)	Additional information
ID	ID	text, 20	
Position	shape/points	geometry (polylineZ)	ETRS-TM35FIN
Link ID	LINK_ID	text, 20	
Start distance from the start of the link	ALKU_M	double	
End distance from the start of the link	LOPPU_M	double	

Validity direction	VAIK_SUUNT	integer	code value
Value	ARVO	integer	centimetre
Last edited	MUOKKAUSPV	text, 50	time stamp "12.06.2014 13:29:17"
Municipality code	KUNTAKOODI	integer	

Lit road

Line

Description	Field (shape)/ Element (WFS)	Data type (shape)	Additional information
ID	ID	text, 20	
Position	shape/ points	geometry (polylineZ)	ETRS-TM35FIN
Link ID	LINK_ID	text, 20	
Start distance from the start of the link	ALKU_M	double	
End distance from the start of the link	LOPPU_M	double	
Last edited	MUOKKAUSPV	text, 50	time stamp "12.6.2014 13:29:17"
Municipality code	KUNTAKOODI	integer	

Paved road

Line

Description	Field (shape)/ Element (WFS)	Data type (shape)	Additional information
ID	ID	text, 20	
Position	shape/points	geometry (polylineZ)	ETRS-TM35FIN
Link ID	LINK_ID	text, 20	
Start distance from the start of the link	ALKU_M	double	

End distance from the start of the link	LOPPU_M	double	
Last edited	MUOKKAUSPV	text, 50	time stamp "12.6.2014 13:29:17"
Municipality code	KUNTAKOODI	integer	

Road affected by thawing

Line

Description	Field (shape)/Element (WFS)	Data type (shape)	Additional information
ID	ID	text, 20	
Position	shape/points	geometry (polylineZ)	ETRS-TM35FIN
Link ID	LINK_ID	text, 20	
Start distance from the start of the link	ALKU_M	double	
End distance from the start of the link	LOPPU_M	double	
Last edited	MUOKKAUSPV	text, 50	time stamp "12.06.2014 13:29:17"
Municipality code	KUNTAKOODI	integer	

Width

Line

Description	Field (shape)/Element (WFS)	Data type (shape)	Additional information
ID	ID	text, 20	
Position	shape/points	geometry (polylineZ)	ETRS-TM35FIN
Link ID	LINK_ID	text, 20	

Start distance from the start of the link	ALKU_M	double	
End distance from the start of the link	LOPPU_M	double	
Road width	ARVO	integer	centimetre
Last edited	MUOKKAUSPV	text, 50	time stamp "12.6.2014 13:29:17"
Municipality code	KUNTAKOODI	integer	

Traffic volume

Line

Description	Field (shape)/ Element (WFS)	Data type (shape)	Additional information
ID	ID	text, 20	
Position	shape/ points	geometry (polylineZ)	ETRS-TM35FIN
Link ID	LINK_ID	text, 20	
Start distance from the start of the link	ALKU_M	double	
End distance from the start of the link	LOPPU_M	double	
Traffic volume	ARVO	integer	vehicles per day
Last edited	MUOKKAUSPV	text, 50	time stamp "12.6.2014 13:29:17"
Municipality code	KUNTAKOODI	integer	

Vehicle specific restriction

Line

Description	Field (shape)/ Element (WFS)	Data type (shape)	Additional information
ID	ID	text, 20	If one restriction includes several prohibited vehicle types, overlapping objects are included in the shapefile. These objects have the same restriction ID.
Position	shape/ points	geometry (polylineZ)	ETRS-TM35FIN
Link ID	LINK_ID	text, 20	
Start distance from the start of the link	ALKU_M	double	
End distance from the start of the link	LOPPU_M	double	
Validity direction	VAIK_SUUNT	integer	code value
Type of prohibited vehicle	KIELL_AJON	integer	code value
Validity period	VOIM_AIKA	Text, 200	
Exceptions	POIKKEUS	text, 40	comma-separated list of exceptions
Last edited	MUOKKAUSPV	text, 50	time stamp "12.06.2014 13:29:17"
Municipality code	KUNTAKOODI	integer	

Name	Code value	Description
Validity direction	1	Both directions
	2	In the direction of digitisation
	3	Against the direction of digitisation
Vehicle type	2	Motor vehicle
	3	Vehicle
	4	Truck
	5	Bus

	6	Delivery vehicle
	7	Passenger car
	8	Taxi
	9	Motorcycle
	10	Moped
	11	Cycle
	12	Pedestrian
	13	Articulated vehicle
	14	Tractor or farm vehicle
	15	Car with trailer / recreational vehicle
	19	Military vehicle
	21	Driving in service purposes
	22	Driving to a lot
	23	Passage through
	26	Horse riding
	27	Snow mobile
	28	Special transport

Restriction for the transportation of dangerous goods (VAK)

Line

Description	Field (shape) /Element (WFS)	Data type (shape)	Additional information
ID	ID	text, 20	If one restriction includes both A-VAK and B-VAK, overlapping objects are included in the shapefile. These objects have the same restriction ID.
Position	shape/ points	geometry (polylineZ)	ETRS-TM35FIN

Link ID	LINK_ID	text, 20	
Start distance from the start of the link	ALKU_M	double	
End distance from the start of the link	LOPPU_M	double	
Validity direction	VAIK_SUUNT	integer	code value
Type of prohibited vehicle	KIELL_AJON	integer	code value
Validity period	VOIM_AIKA	Text, 200	
Last edited	MUOKKAUSPV	text, 50	time stamp "12.06.2014 13:29:17"
Municipality code	KUNTAKOODI	integer	

Name	Code value	Description
Validity direction	1	Both directions
	2	In the direction of digitisation
	3	Against the direction of digitisation
Vehicle type	24	A-VAK
	25	B-VAK

Number of lanes

Line

Description	Field (shape)/ Element(WFS)	Data type (shape)	Additional information
ID	ID	text, 20	
Position	shape/ points	geometry (polylineZ)	ETRS-TM35FIN
Link ID	LINK_ID	text, 20	
Start distance from the start of the link	ALKU_M	double	

End distance from the start of the link	LOPPU_M	double	
Validity direction	VAIK_SUUNT	integer	code value
Number of lanes*	ARVO	integer	number of lanes per carriage way
Last edited	MUOKKAUSPV	text, 50	time stamp "12.06.2014 13:29:17"
Municipality code	KUNTAKOODI	integer	

Public transport lane

Line

Description	Field (shape)/ Element (WFS)	Data type (shape)	Additional information
ID	ID	text, 20	
Position	shape/points	geometry (polylineZ)	ETRS-TM35FIN
Link ID	LINK_ID	text, 20	
Start distance from the start of the link	ALKU_M	double	
End distance from the start of the link	LOPPU_M	double	
Validity direction	VAIK_SUUNT	integer	code value
Validity period	VOIM_AIKA	text, 200	time domain
Last edited	MUOKKAUSPV	text, 50	time stamp "12.06.2014 13:29:17"
Municipality code	KUNTAKOODI	integer	

E-road number

Line

Description	Field (shape)/Element (WFS)	Data type (shape)	Additional information
ID	ID	text, 20	
Position	shape/points	geometry (polylineZ)	ETRS-TM35FIN
Link ID	LINK_ID	text, 20	
Start distance from the start of the link	ALKU_M	double	
End distance from the start of the link	LOPPU_M	double	
E-road number	EURTIENRO	text, 20	comma-separated list of E-road numbers
Last edited	MUOKKAUSPV	text, 50	time stamp "12.06.2014 13:29:17"
Municipality code	KUNTAKOODI	integer	

Exit number

Line

Description	Field (shape)/ Element (WFS)	Data type (shape)	Additional information
ID	ID	text, 20	
Position	shape/points	geometry (polylineZ)	ETRS-TM35FIN
Link ID	LINK_ID	text, 20	
Start distance from the start of the link	ALKU_M	double	
End distance from the start of the link	LOPPU_M	double	

Exit number	LIITT_NRO	text, 20	comma-separated list of exit numbers exit number can also include letters
Last edited	MUOKKAUSPV	text, 50	time stamp "12.06.2014 13:29:17"
Municipality code	KUNTAKOODI	integer	

Winter speed limit

Line

Description	Field (shape)/ Element (WFS)	Data type (shape)	Additional information
ID	ID	text, 20	
Position	shape/points	geometry (polylineZ)	ETRS-TM35FIN
Link ID	LINK_ID	text, 20	
Start distance from the start of the link	ALKU_M	double	
End distance from the start of the link	LOPPU_M	double	
Validity direction	VAIK_SUUNT	integer	code value
Value	ARVO	integer	code value, km/h
Last edited	MUOKKAUSPV	text, 50	time stamp "12.06.2014 13:29:17"
Municipality code	KUNTAKOODI	integer	

Name	Code value	Description
Validity direction	1	Both directions
	2	In the direction of digitisation
	3	Against the direction of digitisation
Value	60	60 km/h
	70	70 km/h
	80	80 km/h

	100	100 km/h
--	-----	----------

Service

Point

Description	Field (shape)/ Element (WFS)	Data type (shape)	Additional information
Service point ID	PALVPISTID	text, 20	If one service point has many services, each of them is presented as an individual data object in service shapefile.
Service ID	PALVELUID	text, 20	
Position	shape/point	geometry (pointZ)	ETRS-TM35FIN
Type of service	TYYPPI	integer	code value
Specifier of the service type	TYYPPI_TAR	integer	code value
Name of service	NIMI	text, 200	
Additional information of the service	LISATIEDOT	text, 200	
Number of parking spaces	PYSPAIKLKM	integer	
Last edited	MUOKKAUSPV	text, 50	time stamp "12.06.2014 13:29:17"
Municipality code	KUNTAKOODI	integer	

Name	Code value	Description
Type of service	4	Customs
	5	Border crossing
	6	Rest area (or lay-by)
	8	Airport
	9	Ferry terminal
	10	Taxi stand
	11	Railway station
	12	Parking lot

	13	Car shipping terminal
	14	Coach and lorry parking (lot?)
	15	Parking house/building
	16	Bus station
Type of rest area	1	Rest area, comprehensive facilities
	2	Rest area, basic facilities
	3	Private service area
	4	No data
Type of railway station	1	Important railway station
	2	Less important railway station
	3	Underground/metro station

Appendix 2. Public transport stop facility data and other attribute data

Attribute data	Tietotyyppi	Description	Code values
Timetable	Code value	Paper copy of a timetable in a frame attached to the stop wall or post. Provides information on departure times for the routes serving the stop and, where applicable, stop-specific estimated passing times.	1 No 2 Yes 99 No data
Shelter	Code value	A weather shelter located in the stop area for the use of waiting public transport passengers.	1 No 2 Yes 99 No data
Advertising shelter	Code value	A weather shelter displaying advertising, located in the stop area for the use of waiting public transport passengers. In this case, the advertiser will be responsible for the stop maintenance.	1 No 2 Yes 99 No data
Bench	Code value	A bench located in the stop area for the use of waiting public transport passengers. Usually placed under the stop shelter.	1 No 2 Yes 99 No data
Electronic timetable board	Code value	An electronic timetable board found in the stop area and providing real-time information for the routes serving the stop.	1 No 2 Yes 99 No data
Lighting	Code value	Stop lighting usually refers to the recessed lighting elements in the stop ceiling that provide light inside the shelter.	1 No 2 Yes 99 No data
Accessibility to persons with reduced mobility	Text field	A stop is accessible if it enables independent travelling and waiting by special passenger groups, such as wheelchair users. Stop accessibility is affected by the stop and platform structures, the station and terminal structures and accessibility of the timetable information.	
Possibility to escort by car	Code value	Indicates whether a stop (by a class I road) has a separate passenger drop-off/pick-up area.	1 No 2 Yes 99 No data

Number of park-and-ride places	Character string	Number of park-and-ride parking spaces by a stop.	
Additional information on park-and-ride	Character string	Free text field for additional information on park-and-ride.	
Stop owner	Character string	Stop owner may be other than the data administrator.	
Feedback address	Character string	Address for sending feedback for the stop. For example, an email address.	
Additional information	Text field	Public comments.	

Appendix 3. Primary data sources by data objects

Primary data source refers to a party that provides or offers data for the Digiroad database. Digiroad also receives feedback maintenance data from other administrators and users. Feedback data is passed on to the primary data source for checking.

Data object	Road owner*	Primary data source
Road link: geometry	State Municipality Private	National Land Survey of Finland National Land Survey of Finland National Land Survey of Finland
Road link: Link ID	State Municipality Private	National Land Survey of Finland National Land Survey of Finland National Land Survey of Finland
Road link: administrative class	State Municipality Private	National Land Survey of Finland National Land Survey of Finland National Land Survey of Finland
Road link: functional class	State Municipality Private	Finnish Transport Agency/DR operator Municipality Municipality
Road link: direction of traffic flow**	State Municipality Private	National Land Survey of Finland / DR operator Municipality Municipality
Road link: link type	State Municipality Private	Finnish Transport Agency/DR operator Municipality Municipality
Road link: bridge, underpass or tunnel	State Municipality Private	National Land Survey of Finland / DR operator Municipality Municipality
Road link: Road name and address data	State Municipality Private	National Land Survey of Finland National Land Survey of Finland National Land Survey of Finland
Road link: road address data	State Municipality Private	Finnish Transport Agency Finnish Transport Agency Finnish Transport Agency
Road link: restricted manoeuvre	State Municipality Private	Finnish Transport Agency Municipality Municipality
Public transport stop***	State Municipality Private	Finnish Transport Agency Municipality Municipality

Barrier	State Municipality Private	In Digiroad, not maintained for the time being National Land Survey of Finland /Municipality National Land Survey of Finland /Municipality
Traffic light	State Municipality Private	Finnish Transport Agency Municipality Municipality
Pedestrian crossing	State Municipality Private	Finnish Transport Agency Municipality Municipality
Directional traffic sign	State Municipality Private	Finnish Transport Agency - -
Railway crossing****	State Municipality Private	Finnish Transport Agency Finnish Transport Agency Finnish Transport Agency
Forest road turnaround point	Private	Metsähallitus
Speed limit	State Municipality Private	Finnish Transport Agency Municipality Municipality
Maximum allowed x 7	State Municipality Private	Finnish Transport Agency Municipality Municipality
Lit road	State Municipality Private	Finnish Transport Agency Municipality Municipality
Paved road	State Municipality Private	National Land Survey of Finland National Land Survey of Finland National Land Survey of Finland
Road affected by thawing	State Municipality Private	Finnish Transport Agency Municipality Municipality
Width	State Municipality Private	Finnish Transport Agency Municipality Municipality
Traffic volume	State Municipality Private	Finnish Transport Agency Municipality Municipality
Vehicle specific restriction	State Municipality Private	Finnish Transport Agency Municipality Municipality

Carriage of dangerous goods (VAK)	State Municipality Private	Finnish Transport Agency Municipality Municipality
Number of lanes	State Municipality Private	Finnish Transport Agency Municipality Municipality
Public transport lane	State Municipality Private	Finnish Transport Agency Municipality Municipality
E-road number	State Municipality Private	Finnish Transport Agency - -
Exit number	State Municipality Private	Finnish Transport Agency - -
Winter speed limit	State Municipality Private	Finnish Transport Agency Municipality Municipality
Service point	State Municipality Private	Finnish Transport Agency Municipality Municipality

**) Road owner corresponds to the road link attribute 'administrative class'.*

****) Direction of traffic flow is provided by the National Land Survey of Finland, but this data can be edited in the Digiroad database, and the National Land Survey of Finland data will not reverse the data edited in Digiroad.*

*****) Public transport stops are maintained jointly by municipalities and ELY Centres. Some municipalities are also competent transport authorities and responsible for the stop material for several municipalities.*

******) The rail track register only provides data on state-owned railway crossings.*

Appendix 4. Route type

Route types are not maintained in Digiroad as data objects. However, a route type can be created based on the administrative class and link type, as shown in the table below.

Route type	Code value	Description
Road	1	Road owner is the state (administrative class = 1) and the road is assigned to motor vehicles (road link type 1-7, 10, 11 or 13).
Street	2	Road owner is a municipality (administrative class = 2) and the road is assigned to motor vehicles (road link type 1-7, 10-13).
Privata road	3	Private road owner (administrative class = 3) and the road is assigned to motor vehicles (road link type 1-7, 10-13).
Pedestrian and cycle path	4	The road is assigned to pedestrian and cycle traffic (road link type 8 or 9).
Ferry	6	The road link type is 21 (ferry/cable ferry).

Appendix 5. Time domain character string

General

Time Domain is defined in GDF and it is a way to indicate precise and complex validity periods for various features and attributes. Notation consists of starting time of the validity period and duration of the validity in the following way: `[(starting time){duration}]`.

For example, `[(M5d1){d1}]` means:

- Starting time: any year in the fifth month on the 1st day at 00:00:00
- Duration: one day (i.e. 24 hours or 1440 minutes)

Starting time

Notations of Time Domain starting time

Unit of time	Compared time	Code	Values (n,x)	Comment
year		ynnnn	0...9999	
month	of year	Mnn	1...12	
week	of year	wnn	1...53	
day	of month	dnn	1...28/29/30/31	maximum depends on month
day	of week	tn	1...7	from Sunday to Saturday
day of week	week of month	fxn	x: 1...5	week from beginning of month from where validity begins
	day of week		n: 1...7	from Sunday to Saturday
day of week	week of month	lxn	x: 1...5	week from end of month from where validity begins
	day of week		n: 1...7	from Sunday to Saturday
hour	of day	hnn	0...23	
minute	of hour	mnn	0...59	
second	of minute	snn	0...59	

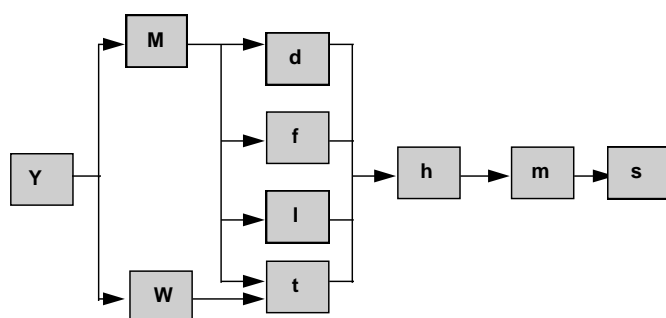

Possible combinations of starting times codes.

Codes are listed from the longest period to the shortest one (y...s). If there is no unit of time marked in the beginning, all values are valid. If there is no unit of time marked in the middle or at the end, the value of the unit is its presumption value, i.e. the smallest possible unit (e.g. M1, w1, d1, h0, m0, s0).

Examples of the notations of starting times:

(y2001)	1.1.2001, 00:00:00
(M5)	every year, 1.5. 00:00:00
(w12)	every year, Sunday on the 12th week, 00:00:00
(d14)	every year, 14th of every month 00:00:00
(t2)	every year, Monday of every week 00:00:00
(f23)	every year, Tuesday of the second week of every month 00:00:00
(l12)	every year, Monday of the last week of every month 00:00:00
(h6)	every year, every day of every month 06:00:00
(m30)	every year, every day of every month, every hour 30:00
(s15)	every year, every day of every month, every hour, every minute :15
(w9h11m30)	every year, every day of the 9th week 11:30:00
(M4m30)	every year, every day of every April, every hour 30:00

Correspondingly:

14th November 2001 (00:00:00)	(y2001M11d14)
every year 2.5. 17:31:00	(M5d2h17m31)
every year, last Sunday of February	(M2l11)

Duration

Duration is the total time of Time Domain notations of time units, e.g. {y2M2w1d2}, which means the validity from starting time onwards, for two years + two months + one week + two days.

A minus sign can be added in front of the duration, e.g. {-d5}, which means the validity on the preceding five days.

Notations of Time Domain duration				
Unit of time	Code	Values (n)	Correspondence	Comments
year	ynn	0...99		Duration ends on the last day of the month if there is no such day in the year when duration ends, e.g. [(y2000M2d29){y2}].
month	Mnn	1...99	{M12}={y1}	Duration ends on the last day of the month if there is no such day in the month when duration ends, e.g. [(y2001M1d31){M1}].
week	wnn	1...99		
day	dnn	1...99	{d7}={w1}	
hour	hnn	0...99	{h24}={d1}	
minute	mnn	0...99	{m60}={h1}	
second	snn	0...99	{s60}={m1}	

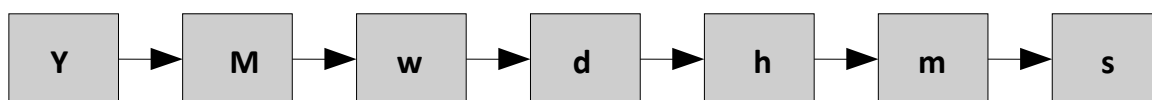

Possible combinations of duration.

Time Domain combinations

There are combination options defined in the Time Domain notations that make it possible to indicate more complex durations. The following options are in use:

- A+B: property is valid in both cases (OR)
- A*B: property is valid when both are valid (AND)
- A-B: property is valid when only A is valid (A AND NOT B)

With combinations the same result can be achieved in several different ways, because e.g. $A*(B+C) = (A*B)+(A*C)$.

Examples

- Every day from 9 a.m. to 1 p.m.
[(h9){h4}]
- Every Friday in March from 7.30 p.m. to 10 p.m.
[(M3t6h19m30){h2m30}]
- The last 15 minutes of the year 2001 (15 minutes before the year 2002)
[(y2002){-m15}]
- Every day from Monday to Saturday between 9 a.m. and 12 noon and between

1.30 and 7 p.m., except on the last Tuesday in January, 1st of May and in August
[[[(h9){h3}]+[(h13m30){h5m30}]]*[(t2){d6}]]-[(M1|13){d1}]-[(M5){d1}]-[(M8){M1}]]