Commodore
Hard Disk Drive

Technical Manual

Model 9060/9090



commodore
COMPUTER

These documents are for repair service information only. Part numbers are for reference only. Only parts on current dealer parts list are available. No license is given for any use by possession of these documents and may not be reproduced in any form without the written approval of Commodore Electronics Limited.

CONTENTS

<u>Section Number</u>	<u>Title</u>	<u>Page Number</u>
SECTION 1	INTRODUCTION TO THE COMMODORE D9060 AND D9090 DISK SYSTEM	
	Introduction	1
1.1	Purpose of The Disk System	1
1.2	Physical Description of The Disk System	1
1.3	Performance Specifications	1
1.4	D9060 and D9090 Disk System Types	6
SECTION 2	OPERATING INSTRUCTIONS	
	Introduction	7
2.1	Unpacking The Disk System	7
2.2	Air Flow	7
2.3	Handling	7
2.4	Preparing The Disk System	7
2.5	Installation	7
2.6	Operation	8
SECTION 3	THEORY OF OPERATION	
	Introduction	9
3.1	Functional Description	9
3.2	IEEE-488 Interface Lines and Signals	10
3.2.1	Control Lines	10
3.2.2	Data Bus Lines	11
3.3	SASI Interface Lines and Signals	14
3.4	TM600 Series Interface	15
3.4.1	Control Input Lines	15
3.4.2	Output Lines	18
3.4.3	Data Transfer Lines	20
SECTION 4	MAINTENANCE	
	Introduction	21
4.1	General Care and Cleaning	21
4.2	Maintenance Inspection	21
4.3	Troubleshooting Guide	21
4.3.1	External Troubleshooting Guide	22
4.3.2	Internal Troubleshooting Guide	25

CONTENTS

<u>Section Number</u>	<u>Title</u>	<u>Page Number</u>
SECTION 5	REPLACEMENT PROCEDURES	
	Introduction	27
5.1	Tools	27
5.2	Top Cover	27
5.3	DOS Board	27
5.4	Controller Board	28
5.5	Disk Drive	28
5.6	Power Supply Board, Linear Supply	29
5.7	Non-Warranty Repair	29
Appendix 1	Major Assemblies	A-1
Appendix 2	Recommended Spare Parts List	A-2
Appendix 3	Schematics and Assemblies	A-3

ILLUSTRATIONS

FIGURES

<u>Figure Number</u>	<u>Title</u>	<u>Page Number</u>
1	Communication Link	9
2	The GPIB Connector Showing Pin Designations. .	11
3	Disk System Block Diagram	13
4	SASI Interface Connections	15
5	Step Mode Timing	18

TABLES

<u>Table Number</u>	<u>Title</u>	<u>Page Number</u>
1	Commodore Disk System Specifications	2
2	Tandon Disk Drive Specifications	4
3	Winchester Disk Controller Specifications . .	5
4	Power Supply Specifications	6
5	IEEE Standard Interface	12
6	Disk Drive Standard Interface	16
7	Maintenance Inspection Checklist	21
8	Hard Disk Power Up Diagnostics, Disk Access Test	23

SECTION 1

INTRODUCTION TO THE COMMODORE D9060 AND D9090 DISK SYSTEMS

INTRODUCTION

This section contains a physical and functional description of the Commodore D9060 and D9090 disk systems, as well as performance specifications. These systems contain a Tandon TM602S or TM603S Winchester disk drive, respectively.

One should study the computer user's manual, the Commodore disk reference manual, and this manual in order to learn the most about these systems.

1.1 PURPOSE OF THE DISK SYSTEM

The D9060 and D9090 disk systems are intelligent peripherals used to increase random access data storage. The disk systems are fully self-contained, and require no operator intervention during operation. They also require no additional computer memory for operation. Hence, one has the same available computer memory whether or not the disk system is being used.

1.2 PHYSICAL DESCRIPTION OF THE DISK SYSTEM

The disk system consists of a Tandon TM602S or TM603S Winchester disk drive, a Winchester disk controller, a disk operating system (DOS) board, and a power supply. These major assemblies and connectors are mounted in one cabinet.

The major components of the disk drive are read/write and control electronics, spindle motor electronics, a spindle motor and disks, a track positioning mechanism, and four or six recording heads.

The Winchester controller board is an intelligent board that uses a bit slice processor (2900 series) to control the Shugart Associates Standard Interface (SASI) and disk drive interfaces.

The DOS board consist of two 6502 microprocessors, one controls the IEEE-488 and one controls the SASI interface; the Commodore disk operating system is also included.

The power supply is a linear supply that provides +12 volts D. C. and +5 volts D. C. from the line voltage.

1.3 PERFORMANCE SPECIFICATIONS

Table 1 contains the performance specifications for the disk system. Table 2 contains the performance specifications for the Tandon TM602S and TM603S disk drives. Table 3 contains the performance specifications for the Winchester controller board. Table 4 contains the performance specifications for the power supply.

TABLE 1
 COMMODORE DISK SYSTEM SPECIFICATIONS

	Model No. D9090	Model No. D9060
Drives Per Unit	1	1
Heads Per Drive	6	4
Formatted Storage Capacity Per System, includes directory	7.52 megabytes	5.01 megabytes
Maximum Sequential File	7.50 megabytes	5.00 megabytes
Maximum Relative File	7.35 megabytes	4.90 megabytes
Disk System		
Buffer RAM	4 kilobytes	4 kilobytes
<u>Disk Formats</u>		
Cylinders	153	153
Sectors Per Cylinder	192	128
Sectors Per Track	32	32
Bytes Per Sector	256	256
Blocks Free (Unit), maximum, Less Bad Sectors and Directory	29,162	19,442
<u>Transfer Rates</u>		
Internal to Unit	5 megabits per second	5 megabits per second
IEEE-488 Bus	1.2 kilobytes per second	1.2 kilobytes per second
<u>Access Times (Milliseconds)</u>		
Track-To-Track	3	3
Average Track	153	153

TABLE 1 (CONTINUED)
 COMMODORE DISK SYSTEM SPECIFICATIONS

	Model No. D9090	Model No. D9060
Head Settling Time	15	15
Average Latency	8.34	8.34
RPM	3,600	3,600
<u>Physical Dimensions</u>		
Height (inches)	5.75	5.75
Width (inches)	8.25	8.25
Depth (inches)	15.25	15.25
Weight (pounds)	21	21
<u>Electrical</u>		
Power (watts)	175	175
Voltage	110-120 volts A. C., 60 Hertz	110-120 volts A.C., 60 Hertz
Fuse	2.0 amperes, 117 volts A. C., slow blow	
MI/Safety Approvals	U. L. and F. C. C.	

TABLE 2

TANDON DISK DRIVE SPECIFICATIONS

	D 70-69	2 7990
	Model No. TM602S	Model No. TM603S
<u>Capacity, Unformatted</u>		
Per Drive	6.4 megabytes	9.6 megabytes
Per Surface	1.6 megabytes	1.6 megabytes
Per Track	10.4 kilobytes	10.4 kilobytes
<u>Number Of</u>		
Platters	2	3
Active Data Surface	4	6
Maximum Flux Reversal Density		
Flux Reversals Per Inch	7690 FRPI	7690 FRPI
Flux Reversals Per Millimeter	303 FRPMM	303 FRPMM
Track Density (Tracks Per Inch)	255 TPI	255 TPI
Cylinders	153	153
Tracks	612	918
Read/Write Heads	4	6
Data Transfer Rate	5.0 megabits per second	5.0 megabits per second
ENVIRONMENTAL SPECIFICATIONS		
<u>Ambient Temperature</u>		
Operating Temperature	39°F to 122°F (4°C to 50°C)	
Nonoperating Temperature	-40°F to 140°F (-40°C to 60°C)	

TABLE 3

WINCHESTER DISK CONTROLLER SPECIFICATIONS

<u>Environmental Limits</u>	<u>Operating</u>	<u>Storage</u>
Temperature (F/C)	32°/0° to 131°/50°	-40°/-40° to 167°/75°
Relative Humidity	10 to 95 percent	10 to 95 percent
Maximum Wet Bulb Temperature	85°F	noncondensing
Altitude	Sea Level to 10,000 feet	Sea Level to 15,000 feet
<u>Power Requirements</u>		
The maximum current requirements are:		
+5 volts D. C. \pm 5 percent at 4.0 amperes		
+12 volts D. C. \pm 10 percent at 0.150 amperes		

TABLE 4
POWER SUPPLY SPECIFICATIONS

Electrical Specifications

5 volts \pm 5 percent at 6 amperes, 5 amperes typical

12 volts \pm 10 percent at 2 amperes, 5 amperes surge for 10 seconds

No more than 50 millivolts Periodic and Random Deviation (PARD) on both +5 and +12 volts

1.4 D9060 AND D9090 DISK SYSTEM TYPES

<u>Top Assembly</u>	<u>Model Number</u>	<u>Differences</u>
300520-001	D9060	117 volts A. C., TM602S, 2 platters
300520-002	D9060	220 volts A. C., TM602S, 2 platters
300520-003	D9090	117 volts A. C., TM603S, 3 platters
300520-004	D9090	220 volts A. C., TM603S, 3 platters
300520-005	D9060	100 volts A. C., TM602S, 2 platters
300520-006	D9060	240 volts A. C., TM602S, 2 platters
300520-007	D9090	100 volts A. C., TM603S, 3 platters
300520-008	D9090	240 volts A. C., TM603S, 3 platters

SECTION 2

OPERATING INSTRUCTIONS

INTRODUCTION

This section of the manual contains information pertinent to unpacking, installation, handling, and operation of the disk system.

2.1 UNPACKING THE DISK SYSTEM

Before unpacking the disk system, inspect the shipping carton for signs of external damage. If the carton is damaged, caution should be exercised when inspecting its contents. The contents and all packing material should be removed from the carton. No packing materials should be discarded until all the contents are located. The carton should contain a Model Number D9060 or D9090 Disk System and a user's manual. If any item is missing, your Commodore dealer should be notified.

2.2 AIR FLOW

Air flow to and from the D9060 and D9090 disk systems must be unrestricted. Failure to allow adequate air flow may result in a power failure.

2.3 HANDLING

Care should be taken whenever the units are moved. The unit should not be moved while the disk drive is in motion. The unit should not be subjected to severe physical shocks i.e., it should not be dropped.

2.4 PREPARING THE DISK SYSTEM

Before connecting the disk system to a power source, verify that the line voltage configuration is correct, and that the power input fuse is installed. See Table 1 for fuse selection.

2.5 INSTALLATION

One of two connector cables are required to connect the disk system to the computer. These cables can be supplied by your Commodore dealer.

PET-to-IEEE cable, Part Number 320101, should be used if the disk system is to be connected directly to the computer.

IEEE-to-IEEE cable, Part Number 905080, should be used if the disk system is to be "aisy chained" to another peripheral device, such as the Commodore Model Number 4022 or any other suitably interfaced printer.

Note

The disk system should be the first peripheral attached to the computer if other devices are to be "daisy chained".

The procedure for connecting the disk system to the computer is:

- Step 1: Power to the computer and all peripherals should be turned off.
- Step 2: The disk drive should be located as close as possible to the computer.
- Step 3: The PET-to-IEEE cable is connected between the IEEE-488 interface on the computer and the disk drive. If additional IEEE devices are to be connected, the IEEE-to-IEEE cable(s) must be used.
- Step 4: The disk unit power cable should be connected to an A. C. outlet at this time, but with its power switch turned off.

2.6 OPERATION

Upon power-on, the unit performs a self-test within the DOS board. For proper operation, the front L. E. D.'s flash twice as the self-test is executed. After a successful self-test, the front panel L. E. D.'s indicate that the unit is in a ready, quiescent condition, i. e., the top L. E. D.'s, unit status is green and the bottom L. E. D., drive activity, is off. Any other state of the L.E. D.'s after power-on indicates a failure within the unit to properly initialize, and one should refer to the troubleshooting guide in this manual.

Normal unit operation should be possible over the IEEE-488 bus, as outlined in the Commodore disk reference manual, after the recommended one minute warm-up time, allowing the disk rotational speed to stabilize.

SECTION 3

THEORY OF OPERATION

INTRODUCTION

This section of the manual contains detailed information about the theory of operation and the interface descriptions of both the disk systems. The discussion begins with a general summary of the disk system functions, followed by a detailed description of the various interface signals. To better understand the function being described, see Appendix 3.

3.1 FUNCTIONAL DESCRIPTION

The disk system conforms to the IEEE-488 interface requirement. It has an IEEE interface connector located on the back panel. The disk system communicates with the host system from the DOS board, which has a 6502 microprocessor that controls the IEEE-488 bus, referred to as the IEEE processor (see Figure 1).

The DOS board has a second 6502 microprocessor that controls the SASI interface communication to the Winchester controller board, referred to as the SASI processor. Communication between the IEEE and SASI processors is via a common accessible random access memory block.

The controller board communicates information between the DOS board and the disk drive.

The disk drive positions the recording heads over the desired track, and reads or writes the data on it.

Figure 3 contains a block diagram that indicates the overall interconnection between the major assemblies within the disk system.

Note

The DOS board has both IEEE-488 and SASI interfaces. The Winchester controller board has the SASI and disk drive interfaces.

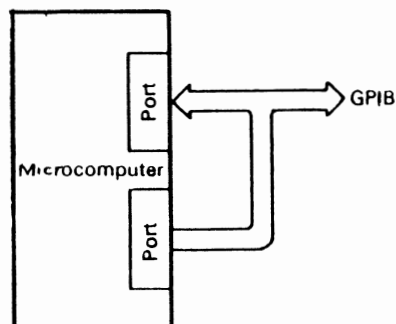

Figure 1
Communication Link

3.2 IEEE-488 INTERFACE LINES AND SIGNALS

The following sections contain a description of the IEEE-488 interface lines and signals. There are two basic groups of lines: control lines and data transfer lines.

3.2.1 Control Lines

Remote Enable (REN)

The Remote Enable line can be activated only by the host system controller. By having a grounded pin, which holds the REN line permanently low (true), the host system enables this line, and bus residing devices subsequently respond to the controller commands or to those of another transmitting device (talker). If this line is allowed to become inactive (false), all bus residing devices return to local control.

Note

On the Commodore computer, Pin 17 is always grounded in the host system.

Service Request (SRQ)

The Service Request line is a type of interrupt line, and it can be activated low (true) by any device that resides on the bus that needs service from the host system.

End or Identify (EOI)

The End or Identify line can be asserted by the controller-in-charge or by a bus-compatible transmitting device. This line may be pulled low (true) by a transmitting device during the transfer of its last data byte in a multiple-byte message to signal the end of the message. A transmitting device has the option of using EOI. However, EOI always is pulled low (true) by the host system during the transfer of its last data byte onto the Data Input/Output (DIO) lines. By using this same EOI signal line and the Attention (ATN) message, the controller-in-charge initiates a parallel poll sequence.

Attention (ATN)

The ATN line is asserted only by the host system during the addressing or command sequence. It can be activated low (true) only by the controller-in-charge to get, as its name implies, the attention of devices that reside on the bus. Before sending commands on the eight data lines to peripheral devices, the host system, acting as the controller-in-charge, activates the ATN line low (true) to tell all devices that signal levels, both true and false, present on the data bus represent addresses and control messages for them.

When the ATN line is returned high, only the transmitting devices and receiving devices previously activated take part in the subsequent data exchange.

Interface Clear (IFC)

The Interface Clear line sends a reset signal that can be initiated only by the host system controller.

When the host system is powered on or reset, this line is driven low (true) for approximately 100 milliseconds by the host internal reset signal, and all bus devices are returned or set to their idle (inactive) states.

Data Valid (DAV)

The Data Valid line is asserted low (true) by a transmitting device after it places its data on the Data Input/Output lines. This tells the receiving device that the information on the data lines is valid.

Not Ready For Data (NRFD)

The Not Ready For Data line, when asserted low (true), indicates that not all devices on the General Purpose Interface Bus (GPIB) are ready to receive data. Each instrument, in its own time, releases this line. However, the line cannot return to its high (inactive) state until the slowest responding device releases this line.

Not Data Accepted (NDAC)

The Not Data Accepted line is controlled by the device or devices that receive the data. This line is held low (true) until all the receiving devices capture the particular address or data byte; then the line is set high.

3.2.2 Data Bus Lines

The GPIB data bus lines (DIO1-8) are similar to typical microprocessor input and output ports. These lines carry eight-bit parallel data to or from the host system.

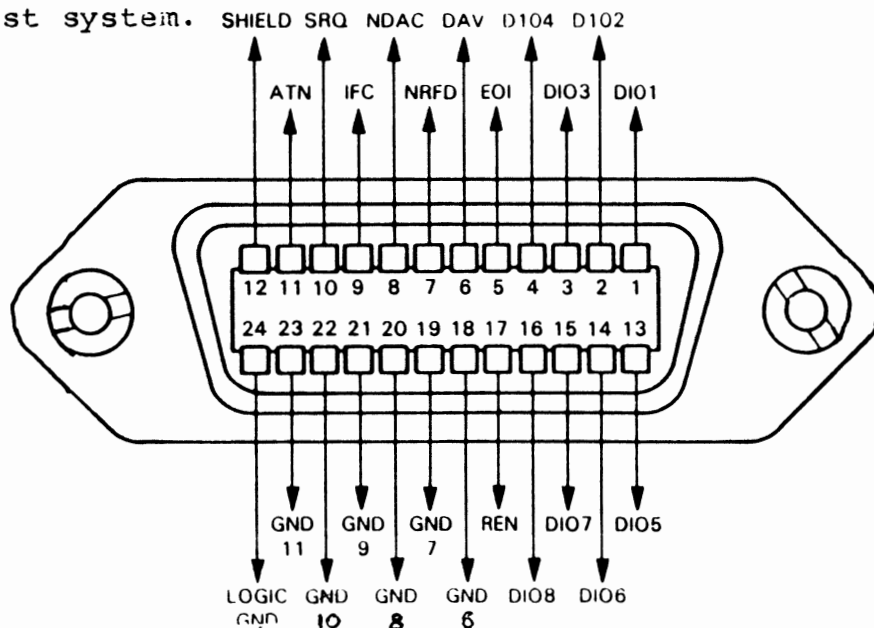

Figure 2
The GPIB Connector Showing Pin Designations

TABLE 5
IEEE STANDARD INTERFACE

IEEE Bus (GPIB) Contact	GPIB Functional Division	IEEE Function Assignment	IEEE Function Description
1	Data Bus	DIO1	Data Input/Output Wire 1
2		DIO2	Data Input/Output Wire 2
3		DIO3	Data Input/Output Wire 3
4		DIO4	Data Input/Output Wire 4
5	Interface Management Bus	EOI	End or Identify
6	Transfer Control Bus	DAV	Data Valid
7		NRFD	Not Ready For Data
8		NDAC	Not Data Accepted (Data Not Accepted)
9	Interface Management Bus	IFC	Interface Clear
10		SRQ	Service Request
11		ATN	Attention
12		SHIELD	GPIB Cable Shield and Chassis Ground
13	Data Bus	DIO 5	Data Input/Output Wire 5
14		DIO 6	Data Input/Output Wire 6
15		DIO 7	Data Input/Output Wire 7
16		DIO 8	Data Input/Output Wire 8
17	Interface Management Bus	REN	Remote Enable (always at ground in the host system)
18	Grounds	GND 6	DAV } NRFD } NDAC } Matching grounds for IFC } these control lines SRQ } ATN }
19		GND 7	
20		GND 8	
21		GND 9	
22		GND 10	
23		GND 11	
24		Logic GND	EOI and REN Grounds

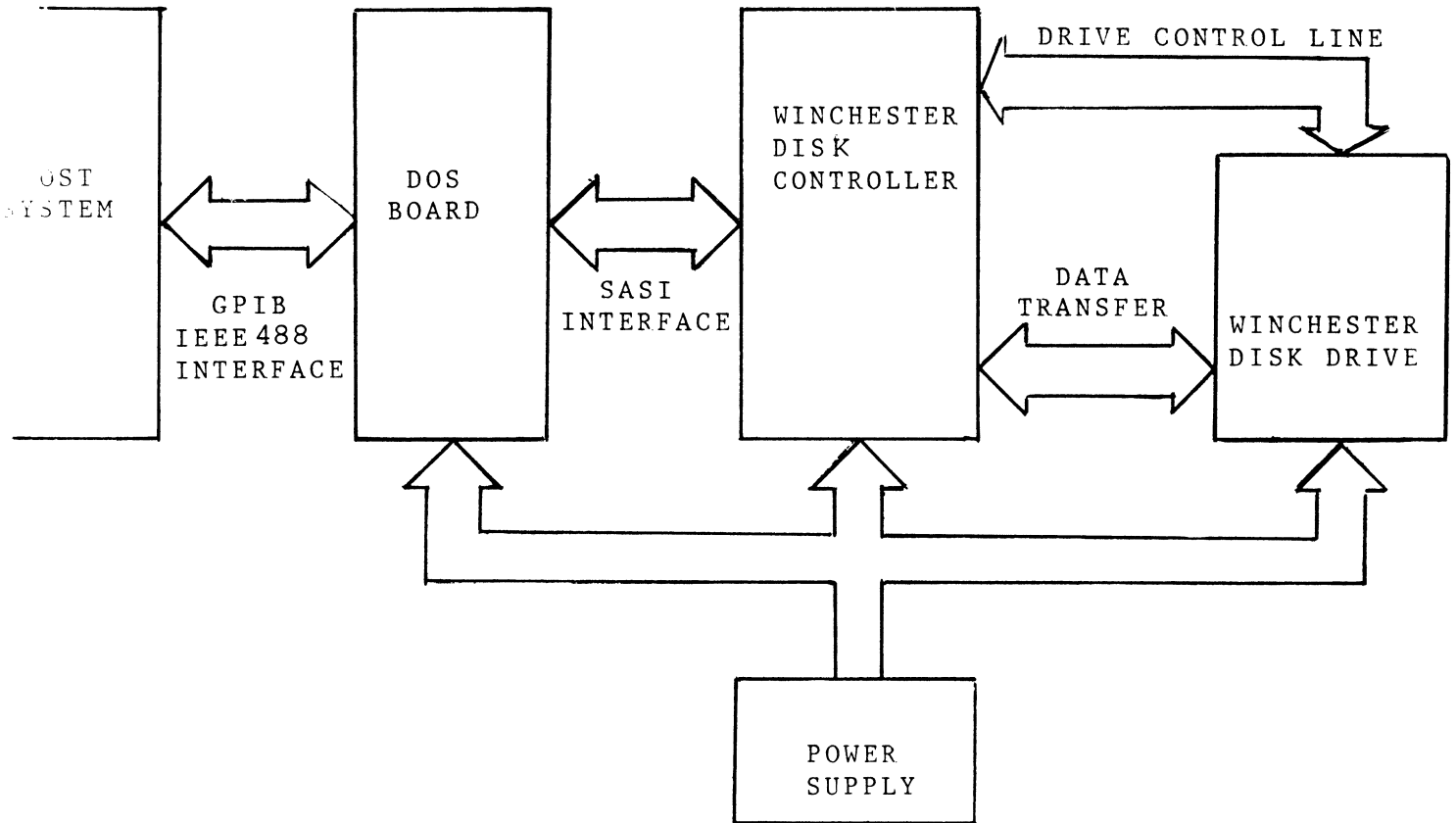

Figure 3
Disk System Block Diagram

3.3 SASI INTERFACE LINES AND SIGNALS

The following contains a description of the SASI type interface lines and signals. This is the communication link between the DOS board and Winchester disk controller.

Reset (RST)

Assertion by the processor causes the disk controller to cease all operations and return to an idle condition. This signal is normally used during a power-up sequence. A reset during a write operation causes incorrect data to be written on the selected disk. The reset pulse should be at least one microsecond wide.

Select (SEL)

Assertion by the processor along with the controller's address bit, Data Bit 0, causes the controller to be selected. The Select line must be deasserted when the disk controller asserts the Busy line.

Busy (BSY)

Assertion by the disk controller indicates that the controller has control of the interface bus and cannot be interrupted.

Control/Data (C/D)

Assertion by the disk controller indicates the command or status information is to be transferred on the data bus, while deassertion of this line indicates that data information is to be transferred on the data bus.

Input/Output (I/O)

Assertion by the disk controller indicates that information is going to be transferred to the processor from the disk controller. Deassertion indicates that information is going to be transferred to the disk controller from the processor.

Request (REQ)

Assertion by the disk controller indicates that an eight-bit byte is to be transferred on the data bus. A request is deasserted after the assertion of the Acknowledge line.

Acknowledge (ACK)

Assertion by the processor indicates that data has been accepted by the processor or that data is ready to be transferred from the processor to the controller.

Message (MSG)

Assertion by the disk controller indicates that a status byte transfer has occurred. When MSG is asserted, REQ is asserted in order to transfer an eight-bit byte to indicate end of operation. When the REQ/ACK handshake is complete, the controller deasserts all interface signal lines and returns to an Idle state.

Data Bus Bits 0-7 (DB)

These bi-directional data lines are used to transfer eight-bit parallel data to and from the processor. Bit 7 is the most significant bit.

Note

There is no parity bit available on the Winchester disk controller.

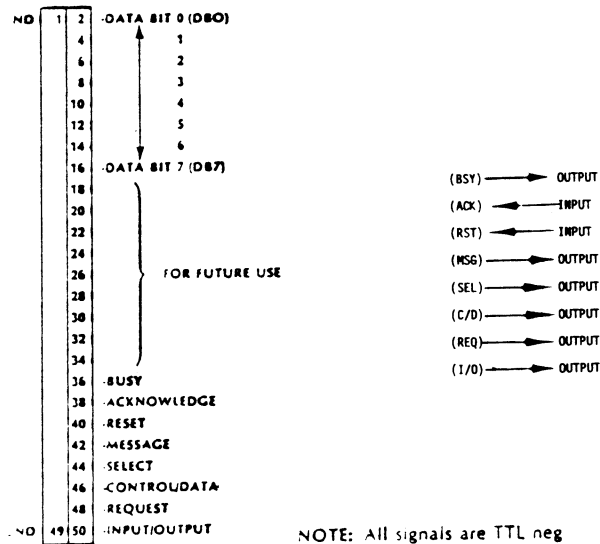

Figure 4

SASI Interface Connections

3.4 TM600 SERIES INTERFACE

The interface for the TM600 series drive is compatible with industry standard drives. Compatibility is defined as using the same pin assignment where the signal and function are common. Table 6 contains pin assignments.

3.4.1 Control Input Lines

The control input signals are of two kinds: those to be multiplexed in a multiple drive system and those that do the multiplexing. The control input signals to be multiplexed are: Reduced Write Current, Write Gate, Head Select Line 2⁰, Head Select Line 2¹, Head Select Line 2², Step, and Direction In. The signal to do the multiplexing is Drive Select 0, Drive Select 1, Drive Select 2 or Drive Select 3.

TABLE 6

Disk Drive Standard Interface

Connector	Pin Number	Signal (Gnd)	Signal Type	I/O	Signal Name
P1 ↑ 34-Pin Ribbon Daisy Chain ↓ P1	2	(1)	S	I	Reduce Write I
	4	(3)	S	-	Head Select 2 ²
	6	(5)	S	I	Write Gate
	8	(7)	S	O	Seek Complete
	10	(9)	S	O	Track 000
	12	(11)	S	O	Fault
	14	(13)	S	I	Head Select 2 ⁰
	16	(15)	-	-	Reserved (To J2-7)
	18	(17)	S	I	Head Select 2 ¹
	20	(19)	S	O	Index
	22	(21)	S	O	Ready
	24	(23)	S	I	Step
	26	(25)	S	I	Drive Select 0
	28	(27)	S	I	Drive Select 1
30	(29)	S	I	Drive Select 2	
32	(31)	S	I	Drive Select 3	
34	(33)	S	I	Direction In	
P2 ↑ 20-Pin Ribbon Daisy Chain or Radial ↓ P2	1	(2)	S	O	Drive Selected
	3	(4)	S	-	Reserved
	5	(6)	S	I	Reserved
	7	(8)	-	-	Reserved (To J1-16)
	9	(10)	-	-	Spare
	11	(12)	-	-	Ground
	13		D	I	+ Write Data
	14		D	I	- Write Data
	15	(16)	-	-	Ground
17		D	O	+ Read Data	
18		D	O	- Read Data	
19	(20)	-	-	Ground	
P3 4-Pin Power Radial P3	1			-	+12 Volt D. C. In
	2			-	12 Volt Return
	3			-	5 Volt Return
	4			-	+5 Volt D. C. In

Notes:

1. S - Single Ended
2. D - Differential
3. I - Drive Input
4. 0 - Drive Output

The input lines have the following electrical specifications, as measured at the drive.

True: 0.0 volts D. C. to 0.4 volt D. C. at Current Load =
-40 milliamperes, maximum

False: 2.5 volts D. C. to 5.25 volts D. C. at Current Open =
250 microamperes, maximum

All input lines share a 220/330 ohm resistor pack for line termination.

Reduced Write Current

When active, this line, together with Write Gate, causes the write circuitry to write on the disk with a lower write current. It is recommended this line be set true when writing is to be done on cylinders 128 and higher, and set false when writing is to be done on cylinders 0 through 127 of the TM602S and TM603S drives.

Write Gate

The active state of this signal or logical zero level enables write data to be written on the disk. The inactive state of this signal enables the data to be transferred from the drive. In addition, the inactive state enables the step pulse to step the read/write actuator.

Head Select Lines 2^0 , 2^1 , 2^2

These three lines provide for the selection of each read/write head in a binary coded sequence. Head Select Line 2^0 is the least significant line. The heads are numbered 0 through 5. When all Head Select Lines are false, Head 0 is selected.

Head recovery time (Head-to-Head Select, Write-to-Read recovery, or Read-to-Write recovery) is 2.4 microseconds maximum.

Step

This interface line is a control signal that causes the read/write head to move with the direction of motion defined by the Direction In line.

The access motion is initiated at the logical true-to-logical false transition or at the trailing edge of this signal pulse. Any change in the Direction In line must be made at least 100 nanoseconds before the true-to-false edge of the step pulse. The quiescent state of this line should be held logically false.

The read/write head moves at the rate of the incoming step pulses. The minimum time between successive steps is 3.0 milliseconds. The minimum pulse width is 1.0 microsecond. Figure 5 contains the step timing.

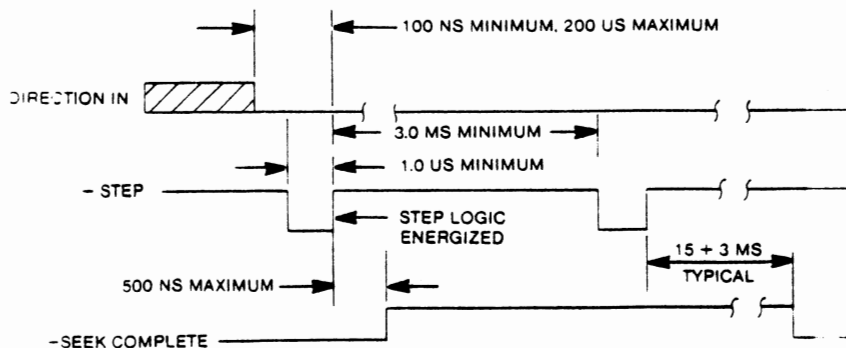

Figure 5

Step Mode Timing

Direction In

This signal defines the direction of motion of the read/write heads when the Step line is pulsed. An open circuit or logical false defines the direction as "out". If a pulse is applied to the Step line, the read/write heads move away from the center of the disk. If this line is logical true, the direction is defined as "in", and the read/write heads move in toward the center of the disk.

Seek Complete must be true prior to changing directions and prior to the application of additional step pulses.

Drive Select 0 Through Drive Select 3

These control signals enable the selected drive's input receivers and output drivers. When logically false, the output drivers are open circuits or logically false and the input receivers do not acknowledge signals presented to them.

Note

On Commodore's D9060 and D9090 systems, the drive is designated as Drive 0.

3.4.2 Output Lines

The output control signals are driven with an open collector output stage capable of sinking a maximum of 40 milliamperes in a logical true state, with a maximum voltage of 0.4 volt measured at the driver. When the line driver is in the logical false state, the driver transistor is off, and the collector cutoff is a maximum of 250 microamperes.

All J1 output lines are enabled by the respective Drive Select lines.

Seek Complete

This line goes true when the read/write heads have settled on the final track at the end of a seek. Reading or writing should not be attempted when Seek Complete is false.

Seek Complete goes false:

1. when a recalibration sequence is initiated by drive logic at power on because the read/write heads are not over Track 000.
2. a maximum of 500 nanoseconds after the trailing edge of a step pulse or a series of step pulses.
3. when power is momentarily lost, Seek Complete is false when power is restored and remains false until an automatic recalibration is completed.

Track 000

This interface signal indicates a true state only when the drive's read/write heads are positioned at Track 000, the outermost data track.

Fault

This signal indicates a condition exists at the drive that could cause improper writing on the disk. When this line is true, further writing is inhibited, as are other drive functions, until the condition is corrected.

A fault signal is initiated by either the +12 volt or +5 volt supply being below the specified limits.

Index

The Index signal is provided by the drive once each revolution, 16.7 milliseconds nominal, to indicate the beginning of the track. Normally, this signal is logical false, and makes the transition to logical true to indicate Index. Only the transition from logical false to logical true is valid.

Ready

When true, the Ready signal, with Seek Complete, indicates that the drive is ready to read, write or seek, and the I/O signals are valid. When this line is false, all controller-initiated functions are inhibited.

The typical time after power on for Ready to be true is 15 seconds. Track 000, Seek Complete, and Ready come true sequentially during power on.

Select Status

A status line is provided at the J2/P2 connector to inform the host system of the selection status of the drive.

The Drive Selected line is driven by a TTL open collector driver. This signal goes active only when the drive is programmed as Drive X (X = 0, 1, 2, or 3) by programming the shunt on the drive, and the Drive Select X line at J1/P1 is activated by the host system.

3.4.3 Data Transfer Lines

All lines associated with the transfer of data between the drive and the host system are differential in nature. These lines are provided at the J2/P2 connector on all drives.

Two pairs of balanced lines are used for the transfer of data: MFM Write Data and MFM Read Data.

MFM Write Data

This is a differential pair of lines that defines the flux transition to be written on the track. The transition of the +MFM Write Data line going more positive than the - MFM Write Data line causes a flux reversal on the track if the Write Gate is active. This signal must be driven to an inactive state (+ MFM Write Data more negative than - MFM Write Data) by the disk controller when in a read mode.

The delay from the leading edge of Write Gate to the Write Data pulse is 400 nanoseconds maximum.

MFM Read Data

The data recovered by reading a prerecorded track is transmitted to the host system via the differential pair of MFM Read Data lines. The transition of the +MFM Read Data line going more positive than the - MFM Read Data line represents a flux reversal on the track of the selected head.

SECTION 4

MAINTENANCE

INTRODUCTION

Preventive maintenance consists of visual inspection, cleaning and checking the disk system performance. The severity of the environment in which the disk system is used determines the frequency of maintenance. When accomplished on a regular basis, preventive maintenance may prevent damage and enhance the system's reliability.

4.1 GENERAL CARE AND CLEANING

The cabinet reduces the accumulation of dust inside the disk system since dirt may cause overheating and early component breakdown. Dirt on components acts as an insulating blanket preventing effective heat dissipation. Dirt also provides a conductive electrical path that can cause system failure.

To clean the interior of the disk system, blow the dust off with low pressure air, and remove the remaining dust with a soft brush or soft damp cloth. A cotton tipped applicator is useful for cleaning narrow spaces and printed circuit boards.

4.2 MAINTENANCE INSPECTION

Inspect the disk system for physical damage or wear, using Table 7 as a guide.

Table 7

Maintenance Inspection Checklist

<u>Item</u>	<u>Inspect for</u>
Cabinet and Chassis	Dents, deformations, and damaged hardware
Wiring and Cables	Loose plugs, loose connectors, burned, broken or frayed wiring
Circuit Boards	Corroded or cold solder joints. Burned broken or cracked circuitry. Burned, cracked or broken components.

4.3 TROUBLESHOOTING GUIDE

This troubleshooting guide consists of two sections: an external guide which contains tests and diagnostics that may be conducted while the unit is still unopened, and an internal guide which contains tests that must be conducted while the system is open and the boards are accessible.

4.3.1 External Troubleshooting Guide

Physical Examination

Check for any physical damage, especially that which would indicate the unit was dropped. If the unit appears to have been dropped, open the system, see the replacement guide, and verify that all items are in place.

Check the unit fuse. If blown, replace the fuse, and perform all internal checks before proceeding.

Functional Test--Internal Self-test

Turn on the unit's power, and watch the front panel L. E. D's. The L. E. D's should flash twice, then stay in the ready/quiescent condition: unit status L. E. D. green, and drive access L. E. D. off. If the unit passes the internal self-test, it is ready for a system test.

If the unit L. E. D's are not on, proceed to the internal tests.

If the unit L. E. D's are flashing some number of flashes, followed by a pause, forever repeating, the system is nonfunctional, and Table 3 gives one an idea which circuit is inoperative on the DOS board.

Note

Prior to changing the DOS board, proper voltage should be verified on it. High voltage on the +5 volt lines also causes repetitive flashing.

Replace the DOS board (see the replacement procedure section) or the regulator board if the voltage is too high and cannot be adjusted (see Table 4, page 6).

System Test

IEEE-488 Interface Test

Enter the following lines into the computer:

```
5 rem Program 1
10 Open 15, 8, 15: rem open disk drive unit
20 a$="": c$ = "": d$= "": s$ =: rem initialize variables
30 Print: Number 15, "uj": rem initialize disk unit
40 Input: 15, a$, b$, c$, d$: rem get variables from drive
50 Print: a$ s$ b$ s$ c$ s$ d$: rem display variables on screen
60 Close: 15: rem disk unit
```

TABLE 8

HARD DISK POWER UP DIAGNOSTICS,
DISK ACCESS TEST

Number of Flashes	Possible Faulty IC Located On DOS Board
1	6532, 7F 7G
2	2364, 7D
3	2364, 7C
4	6502, 2114, 74LS157, 74LS42, 4A, 5A, 5E, 6C, 6D, 6B, 6A, 3D
5	6810, 4D
6	2114, 74LS157, 5E, 5A, 6C, 6D, 6B, 6A
7	2114, 74LS157, 5B, 5F, 6C, 6D, 6B, 6A
8	2144, 74LS157, 5C, 5G, 6C, 6D, 6B, 6A
9	2114, 74LS157, 5D, 5H, 6C, 6D, 6B, 6A
10	2332, 4C
11*	Not used
12*	74LS157, 6C, 6D, 6B, 6A
13	74LS157, 6C, 6D, 6B, 6A
14	74LS157, 6C, 6D, 6B, 6A

* During Format 11, 12 flashes, excessive bad sectors

PROGRAM 1

This program assumes that the unit under test (UUT) is the only device Number 8 on the IEEE-488 bus.

The correct response from the unit should be: 73, CBM DOS V3.0,00,00

If the response is good, the IEEE-488 communication is correct.

If the response is not correct, verify that the UUT is the only device Number 8 on the IEEE-488 bus, and that the IEEE cable is properly connected. If so, the IEEE-488 interface on the DOS board is non-functional, and the DOS board should be replaced as specified in the replacement procedure section.

Disk Access Test

Enter the following lines into the computer:

```
load "$0", 8
list
```

This loads the directory from the disk to the computer, assuming the disk has a readable directory. If the unit fails this test, it would be advisable to proceed to the internal tests, and verify proper interconnections, and power. If no problem is found, the problem is in the DOS, the controller, or the drive. The drive, which may contain user data, should be the last item checked or replaced. The controller board is the next suspect, then the DOS. If the unit is functional, it should be reassembled.

Caution

If the drive still fails to read, the disk may be reformatted. This destroys any user data that is on the drive. The lost data cannot be recovered.

The drive can be reformatted by issuing a header "diskname, 00" (basic <4.0). These commands may take up to one hour and forty-five minutes on a D9090 unit. If the drive still cannot be read, replace the disk drive (see the replacement procedure).

If the unit fails during format, for example, 11 flashes occur, there is a problem either with the drive or with the controller. It is recommended the controller be replaced first, and the drive only if necessary.

If the unit status L. E. D. is red, indicating failure, the unit status may be displayed by using Program 1, without line 30. If the unit status indicates the drive is not ready, and the drive is formatted, it is probably bad, and should be replaced (see replacement guide).

If the unit loads the directory properly, the unit is functional. One may store a program on the disk, read, and execute it to verify the read/write process within the unit.

4.3.2 Internal Troubleshooting Guide

Electrical Connections (see Appendix 3)

Verify that all cables are properly connected.

Linear power supply connectors are installed.

The connector from the transformer is connected to the power supply board.

Two wires are connected to the filter capacitor.

The chassis ground is connected to the chassis.

The DOS power connector is installed.

The controller power connector is installed.

The drive power connector is installed.

The DOS to controller flat ribbon cable is connected.

The two controller to drive flat ribbon cables are connected.

The DOS to L. E. D's cable is installed.

Note

If this cable is incorrectly installed, the L. E. D's flash with an incorrect pattern. At location on the controller board, a jumper clip (J1 on top assembly) is installed. Without this jumper, the controller never sees data from the drive, and thinks that the drive is inoperative.

Internal Testing

The most important test to be conducted is to verify the +5 volt and +12 volt operation of the power supply. This may be accomplished by looking at the voltage potential across the +5 volt and +5 ground test points, and the +12 volt and +12 ground test points on the power supply board. The +5 volt is common to all +5 logic; the +12 volt is common on both the drive and controller. A voltmeter or an oscilloscope may be used to examine these voltage potentials. Adjustment pots to adjust the +5 volt and +12 volt potentials are accessible on the power supply board. The adjustment pot nearest the heatsinks is the +5 volt adjustment pot; the other one is the +12 volt adjustment pot.

Tolerances on both should be plus or minus five percent. If the supply cannot be adjusted to within five percent, replace the power supply (see replacement guide), then repeat this test. If the new power supply board cannot be adjusted and the supply is low, disconnect the drive, the controller, and the DOS boards, one at a time, and replace the unit that is loading down the supply.

At this point, the functional test should be conducted on the disk system. If any failures are found, the item diagnosed as defective should be replaced. If the disk system passes the functional test, it should be closed in, then screws and fasteners reinstalled, and the top cover put into place. Then, repeat the functional test. If no errors are found, the disk system is considered good.

SECTION 5

REPLACEMENT PROCEDURES

INTRODUCTION

The assembly drawings (see Appendix 3) are intended to help one remove and reinstall individual assemblies or components.

Replacement Guide

Caution

To prevent shock hazard, always disconnect the unit from the primary source prior to disassembling the unit.

This section contains a step-by-step approach in disassembly of the D9060 or D9090 disk system. Each of the steps assumes that the previous ones have been performed. The system may be reassembled by reversing the order of the steps. A recommended parts list for the system is found in Appendix 2.

5.1 TOOLS

The tools needed to disassemble and reassemble the system are:

1. Phillips Screwdriver, Number 2
2. slot screwdriver
3. needlenose pliers
4. 11/32-inch socket or open end wrench

5.2 TOP COVER

Remove four screws, two on each side.
Lift top cover up and remove.

5.3 DOS BOARD

Disconnect the DOS power. The connector is located on the bottom side of the DOS board, at the rear of the unit. Disconnect the 50 Pin DOS-controller interface cable, located on the top front of the DOS board. The slotted screwdriver is useful in removing the cable.

Disconnect the L. E. D. interconnect cable, located on the top front cover of the DOS board.

Remove the four screws that connect the DOS board, located on both of its edges, toward the front of the system.

Remove the DOS board and the DOS shield, if it is installed on the system.

→ When replacing the DOS Board, be sure jumper J14 is installed for the D9090 system, and not installed for the D9060 system.

5.4 CONTROLLER BOARD

Disconnect the controller power, located on the bottom side of the controller board at the rear of the unit.

Disconnect the 50-pin DOS-controller cable to J2. Care should be taken not to pull on the cable itself during removal.

Disconnect the 20-pin cable from J3 on the controller board. Care should be taken not to pull on the cable during removal.

Disconnect the 34-pin cable from J1 on the controller board. Care should be taken not to pull on the cable during removal.

Unscrew the fiber standoffs that hold on the controller board. Standoffs are located on the edges of the controller board toward the front of the unit.

Remove the controller board, and the disk drive shield.

Remove the four white spacers located on the four adapter screws that protrude through the shield.

Remove the disk drive's shield. Note the shield is copperside down, i. e., facing the drive.

Disconnect the 34-pin cable from disk drive connector J1.

Disconnect the 20-pin cable from disk drive connector J2.

Note

Continue to remove the power supply, fan, transformer, and other miscellaneous items at the rear of the unit without removing the disk drive.

5.5 DISK DRIVE

Disconnect the drive's power cable from the disk unit, located at the rear of the disk unit, connected to the bottom of the disk's circuit board. Needlenose pliers are useful. Remove the four screws mounting the disk system to the chassis, located on the side of the system. Care should be taken not to let it drop as the second screw is removed from each side. Lift the drive out of the chassis.

5.6 POWER SUPPLY BOARD, LINEAR SUPPLY

Disconnect the primary windings by disconnecting the transformer cable plugged into the power supply board. Remove four 11/32-inch nuts on the bottom of chassis that hold the transformer in place. (Caution: the transformer is heavy.) Remove the screws on either side of the high voltage cover. Remove the power supply board by depressing the plastic restraining latch on each standoff. Then, lift the power supply board and the high voltage cover out of the system.

Transformer

The transformer may be removed by unsoldering the primary connections on the switch and power connector. The fan, switch, power connector, and fuse may be unsoldered and replaced, when physically damaged.

5.7 NON-WARRANTY REPAIR

All Tandon Service Centers are available for repair. The cost of freight is paid by the customer both ways.

Tested spare subassemblies are available. Purchase orders are processed by Tandon Corporation's Order Entry Department.

All repaired parts and services are covered under Tandon Corporation's nine month warranty.

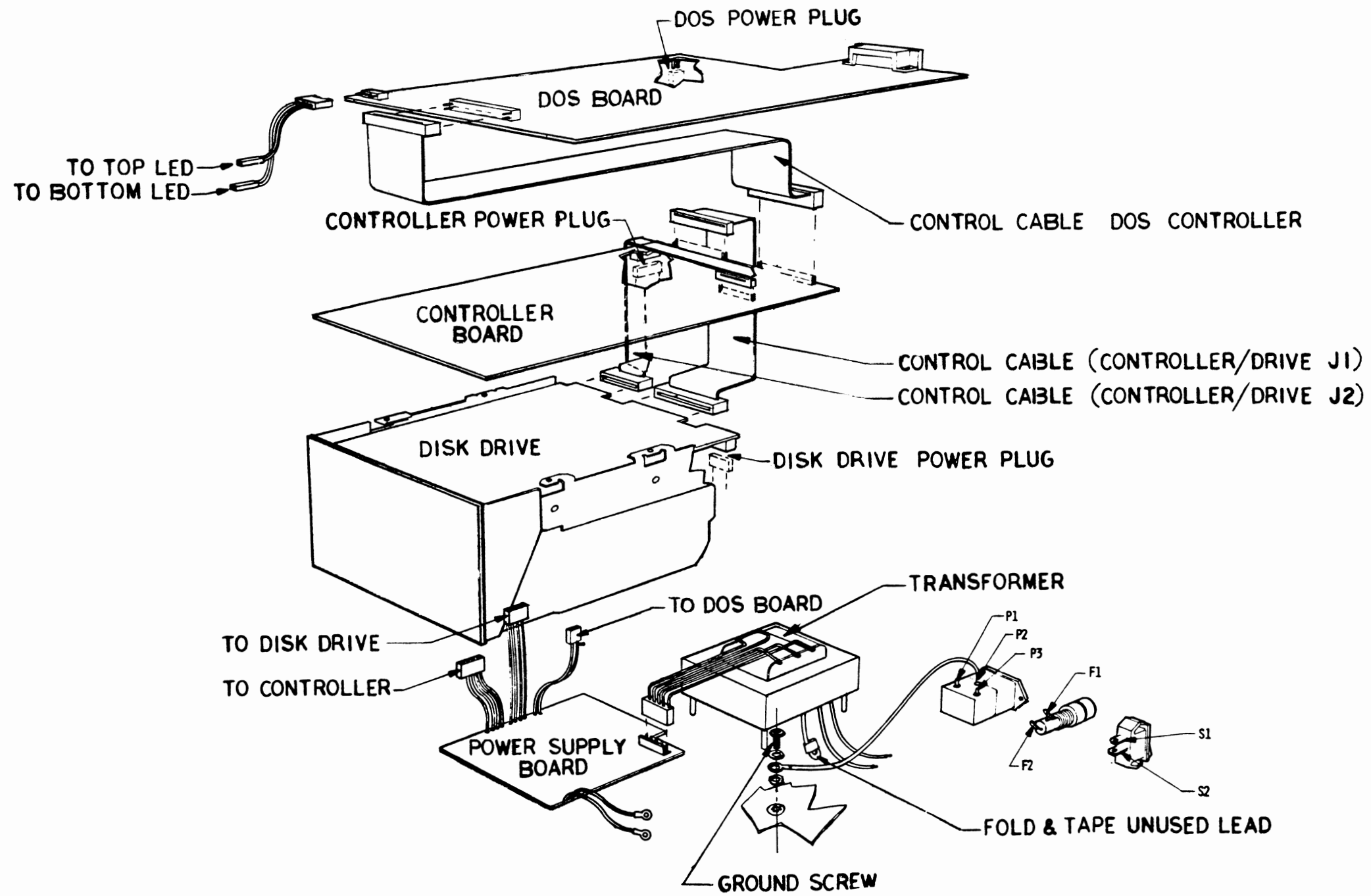

TITLE			
COMMODORE DISK SYSTEM			
SIZE	DATE	DWG NO.	REV
B	11/5/82	300520-00X	D
SCALE	NONE	DO NOT SCALE DWG	SHEET 1 OF 2

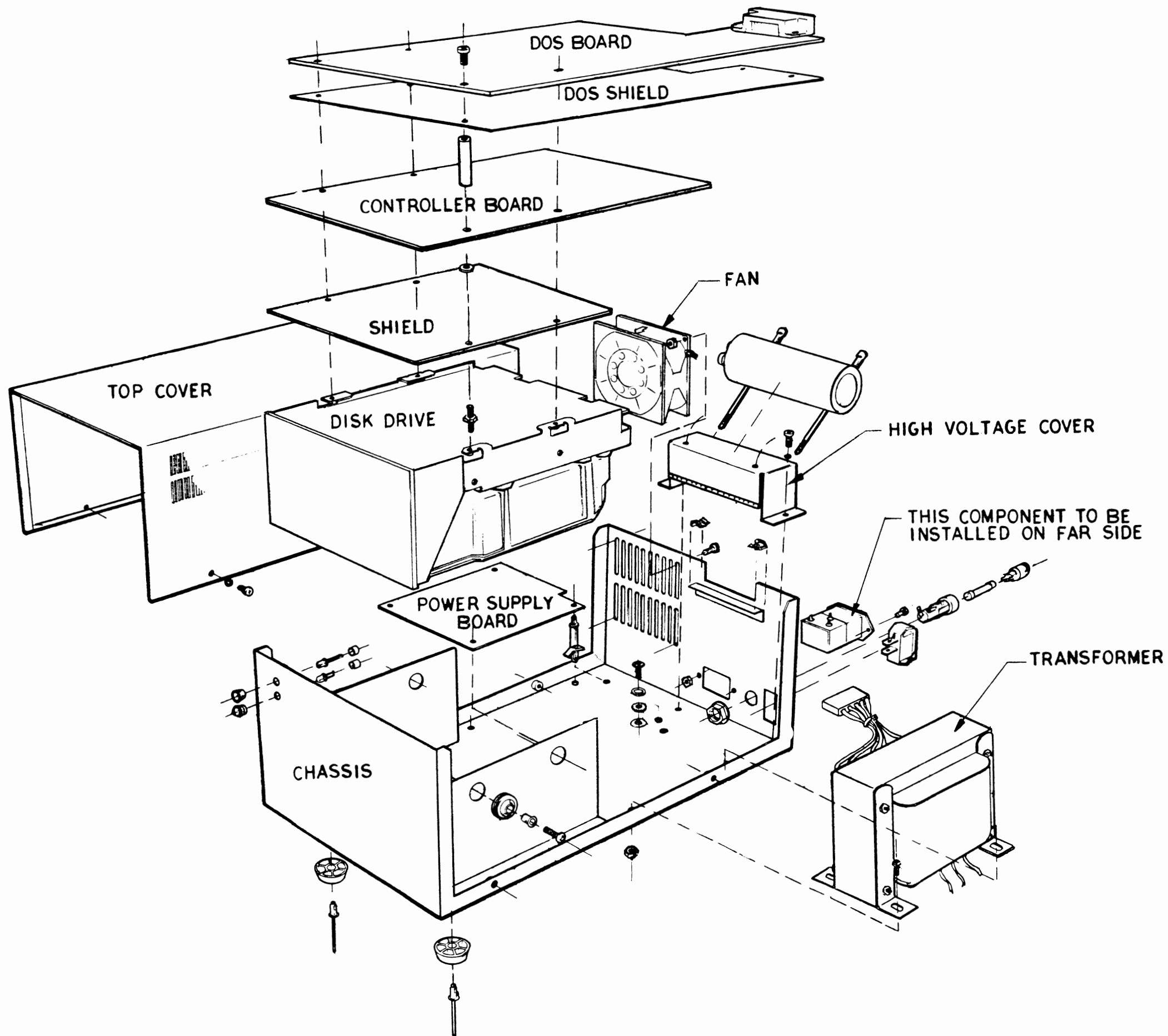

TITLE			
COMMODORE DISK SYSTEM			
SIZE	DATE	DWG NO.	REV
B	11/5/82	300520-00X	D
SCALE	NONE	DO NOT SCALE DWG	SHEET 2 OF 2

REVISIONS				
REV	DESCRIPTION	DATE	DR	CHK
A	RELEASE TO PROD PER E.O.# 30323	4/86	4/10	4/10

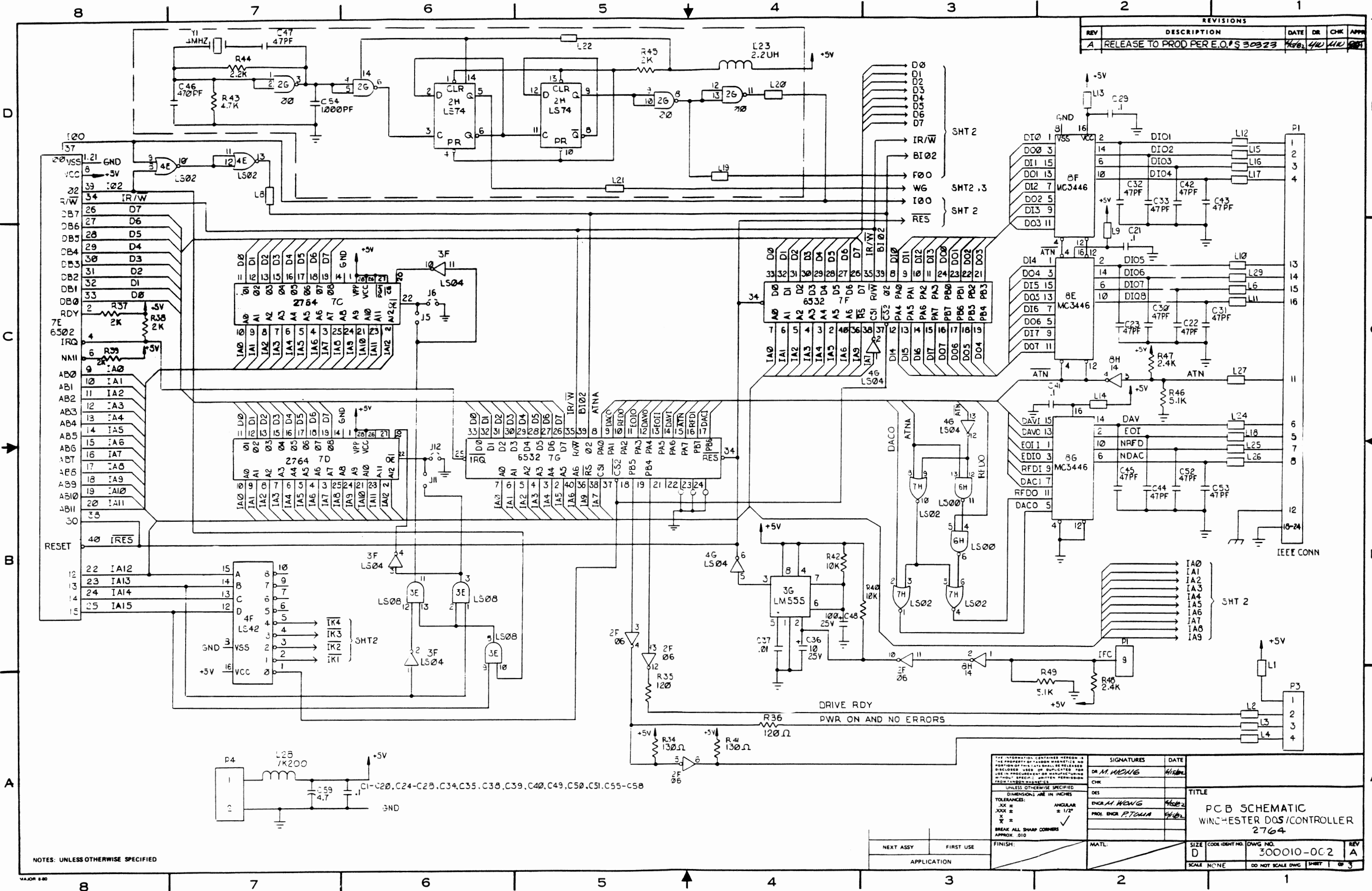

NOTES: UNLESS OTHERWISE SPECIFIED

SIGNATURES		DATE	TITLE
DR	M. WONG	4/86	
CHK			
DES	ENGR. M. WONG	4/86	SIZE CODE IDENT NO. DWG NO.
	PROJ. ENGR. P. TOMA	4/86	
FINISH:			SCALE
NEXT ASSY	FIRST USE	APPLICATION	DO NOT SCALE DWG
			SHEET 1 OF 3

REVISIONS				
REV	DESCRIPTION	DATE	DR	CHK
1	SEE SHEET 1			

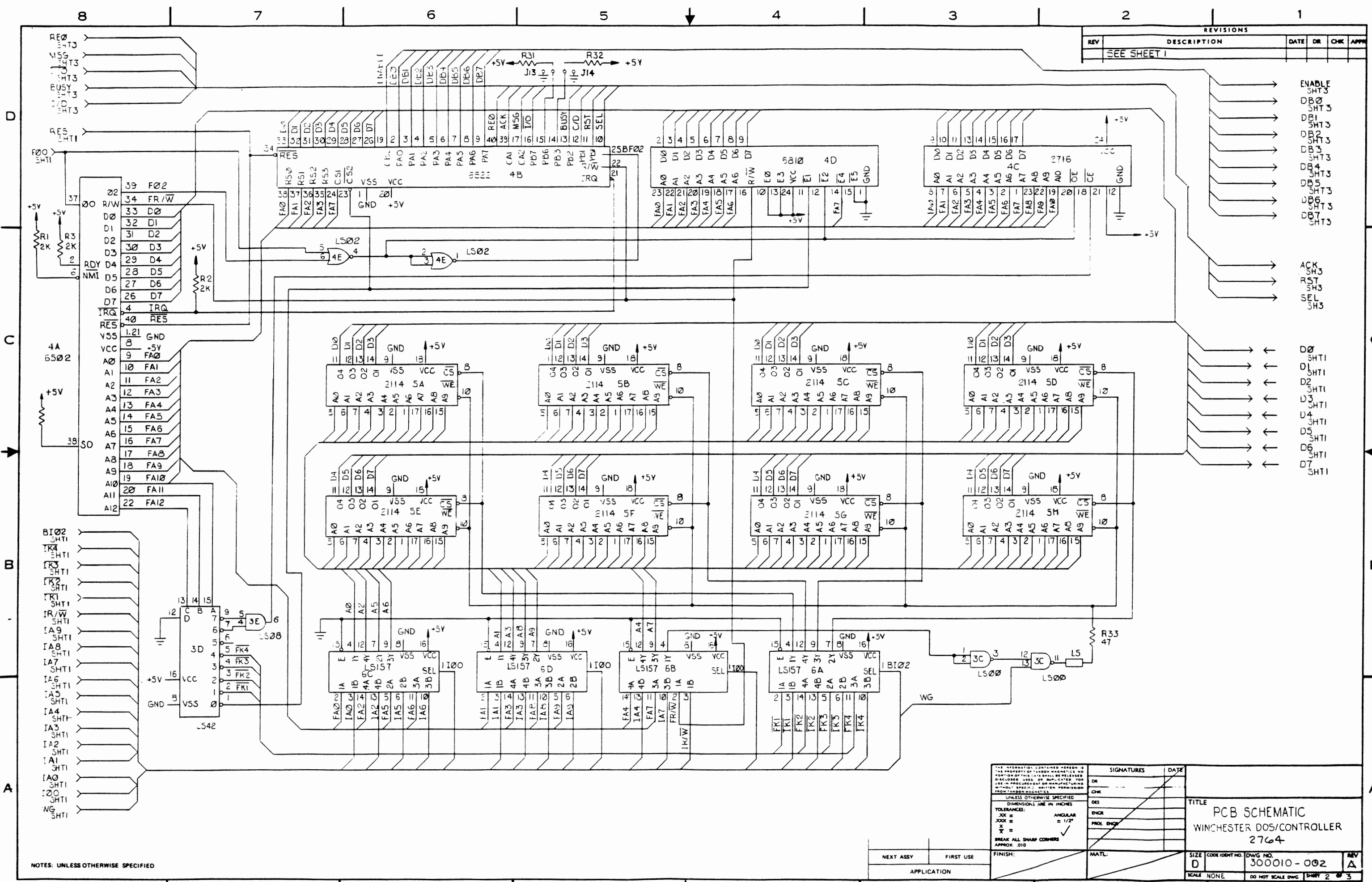

- ENABLE SHT3
- DB0 SHT3
- DB1 SHT3
- DB2 SHT3
- DB3 SHT3
- DB4 SHT3
- DB5 SHT3
- DB6 SHT3
- DB7 SHT3
- ACK SHT3
- RST SHT3
- SEL SHT3
- D0 SHT1
- D1 SHT1
- D2 SHT1
- D3 SHT1
- D4 SHT1
- D5 SHT1
- D6 SHT1
- D7 SHT1

<small>THE INFORMATION CONTAINED HEREON IS THE PROPERTY OF RAND MAGNETICS NO PORTION OF THIS DATA SHALL BE RELEASED EXCEPT AS AUTHORIZED BY RAND MAGNETICS FOR USE IN PROCUREMENT OR MANUFACTURING WITHOUT SPECIFIC WRITTEN PERMISSION FROM RAND MAGNETICS</small>		SIGNATURES		DATE
<small>UNLESS OTHERWISE SPECIFIED TOLERANCES ARE IN INCHES XX = ANGULAR XXX = 1/2" X = BREAK ALL SHARP CORNERS APPROX. 0.10</small>		DR		
<small>FINISH:</small>		ENGR		
<small>APPLICATION</small>		PROJ. ENGR		
<small>MATL:</small>				
<small>SCALE NONE</small>		TITLE PCB SCHEMATIC WINCHESTER DOS/CONTROLLER 2764		
<small>DO NOT SCALE DWG</small>		<small>SIZE</small> D	<small>CODE IDENT NO.</small> 300010-002	<small>REV</small> A
<small>DO NOT SCALE DWG</small>		<small>SCALE NONE</small>	<small>DO NOT SCALE DWG</small>	<small>SHEET 2</small>

NOTES: UNLESS OTHERWISE SPECIFIED

REVISIONS					
REV	DESCRIPTION	DATE	DR	CHK	APP
SEE SHEET 1					

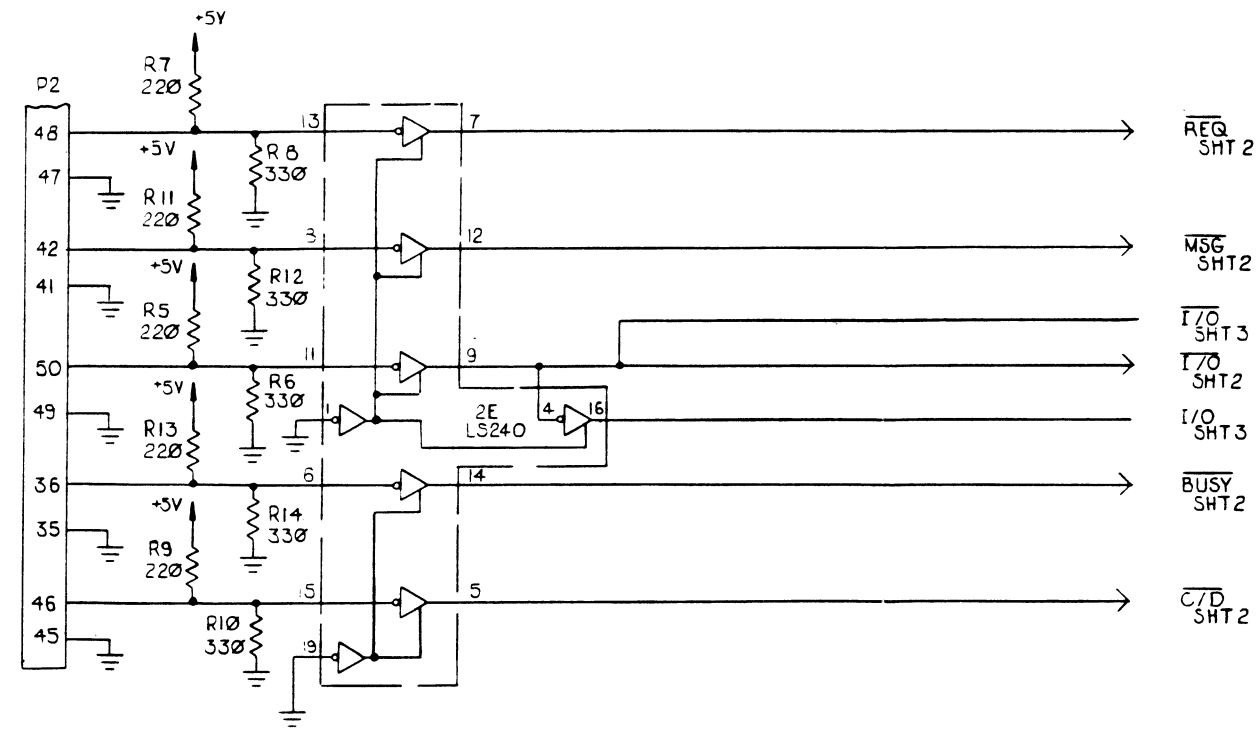
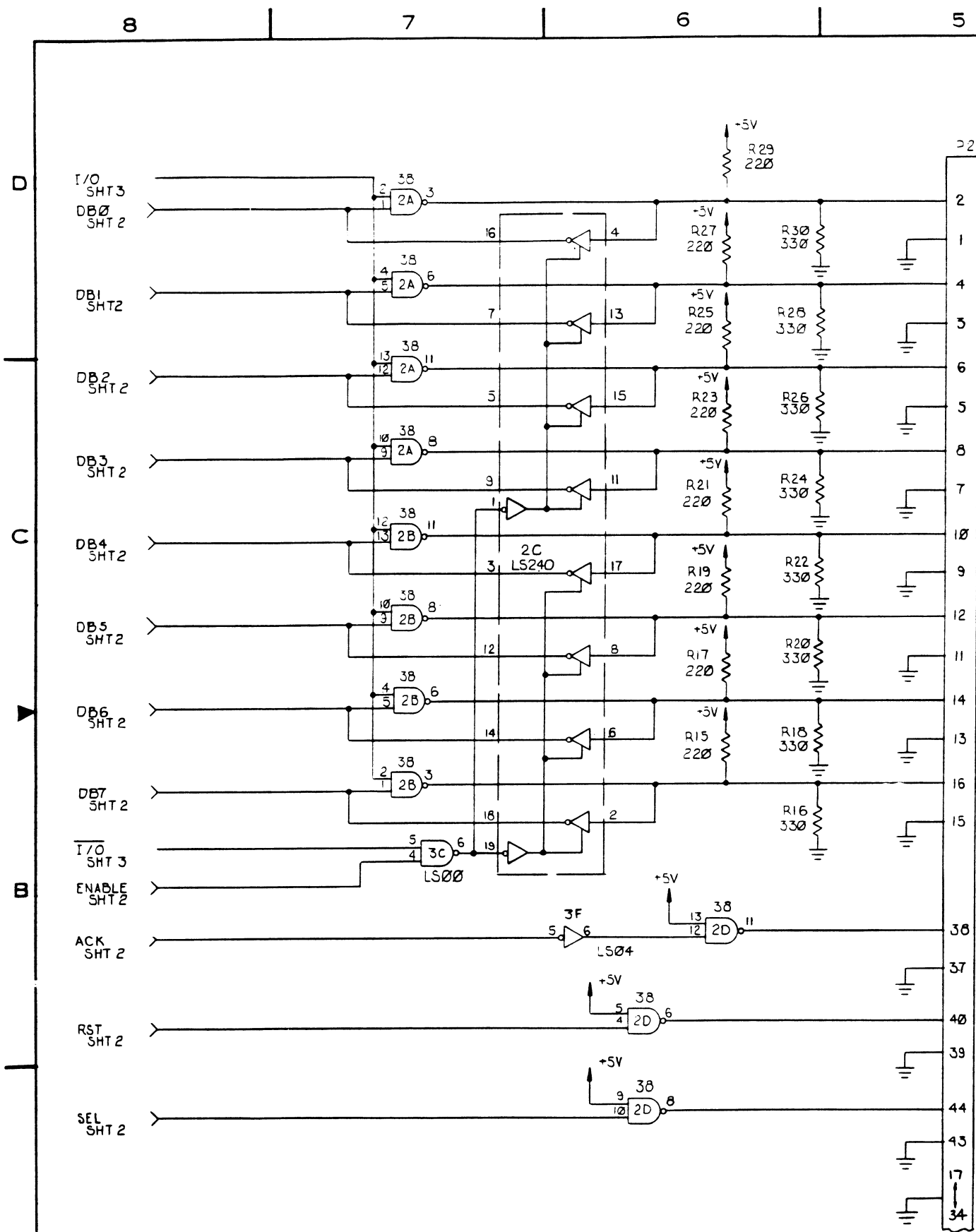

NOTES: UNLESS OTHERWISE SPECIFIED

<small>THE INFORMATION CONTAINED HEREON IS THE PROPERTY OF TANDON ELECTRONICS. NO PORTION OF THIS DATA SHALL BE RELEASED OR DISCLOSED, USED, OR REPRODUCED FOR USE IN PROCUREMENT OF MANUFACTURING WITHOUT SPECIFIC WRITTEN PERMISSION FROM TANDON ELECTRONICS.</small>		SIGNATURES		DATE
<small>UNLESS OTHERWISE SPECIFIED DIMENSIONS ARE IN INCHES</small>		DR		
<small>TOLERANCES:</small> .XX ± .XXX ± .X ± X ±		CHK		
<small>ANGULAR ± 1/2°</small> BREAK ALL SHARP CORNERS APPROX. .010		DES		
FINISH:		ENGR		
APPLICATION		PROJ. ENGR		
NEXT ASSY		MATERIAL		
FIRST USE		TITLE P.C.B SCHEMATIC WINCHESTER DOS/CONTROLLER 2764		
SCALE		SIZE D		DWG NO. 300010-C02
DO NOT SCALE DWG		SHEET 3 OF 3		REV A

8 7 6 5 4 3 2 1

REVISIONS						
REV	DESCRIPTION	DATE	DR	CHK	APP	
A	RELEASE TO PRODUCTION PER CD 50036					
B	REVISE PER CD 55009					

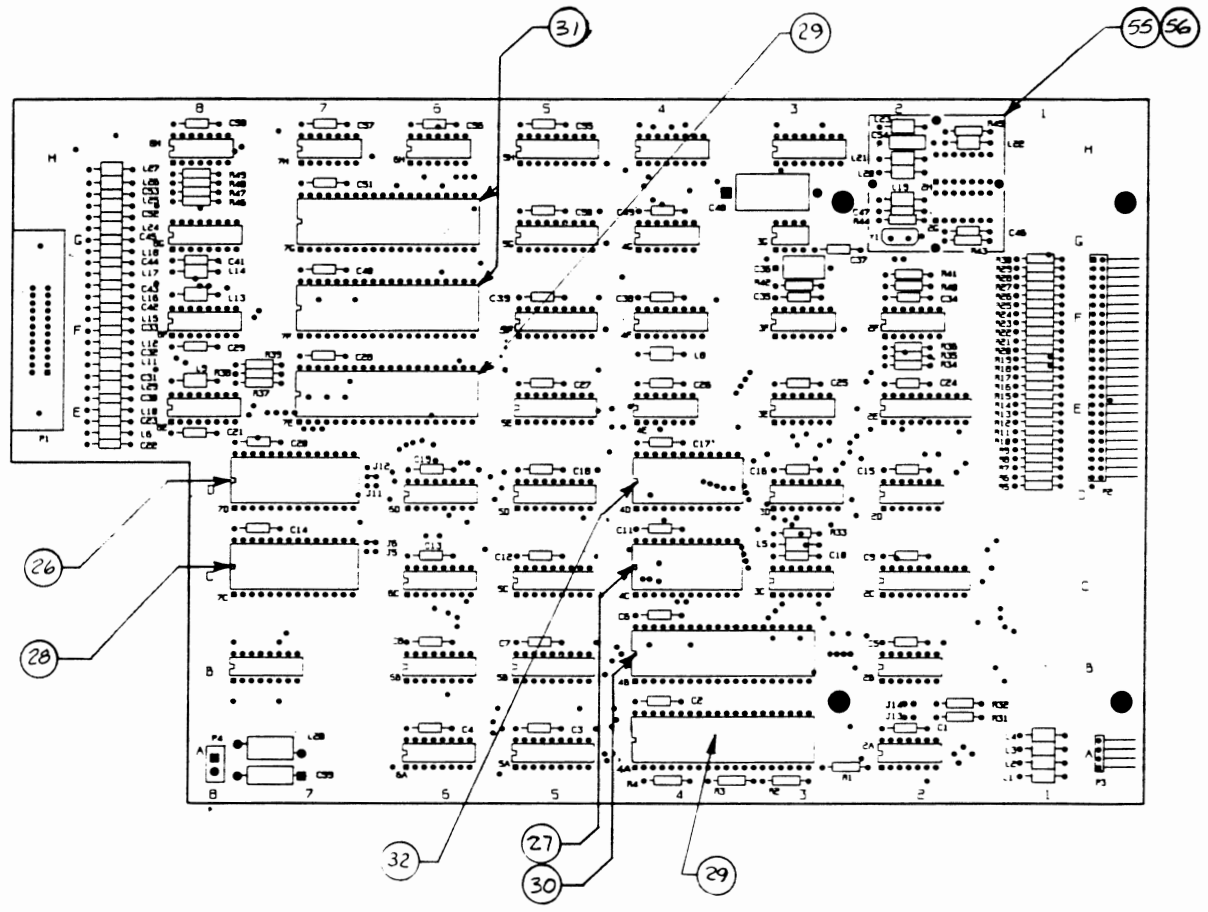

1. FOR OTHER COMPONENT LOCATION, REFER TO BOARD DESIGNATION AND BVM.
 NOTES: UNLESS OTHERWISE SPECIFIED

<small>THE INFORMATION CONTAINED HEREON IS THE PROPERTY OF TADSON MACHINE CO. AND NO PORTION OF THIS DATA SHALL BE RELEASED OR DISCLOSED IN ANY MANNER WITHOUT THE WRITTEN PERMISSION OF TADSON MACHINE CO.</small>		SIGNATURES DR. M. WONG CHK. DES. ENGR. PROJ. ENGR. P.M.T. MATL.		DATE 8/20 8/20
<small>UNLESS OTHERWISE SPECIFIED, DIMENSIONS ARE IN INCHES</small>		TITLE PCB ASSY WINCHESTER DOS/CONTROL 2764		SIZE D
TOLERANCES: .XX ± .005 .XXX ± .010 .X ± .005 .X ± .005 BREAK ALL SHARP CORNERS APPROX. .010		FINISH APPLICATION		CODE IDENT NO. 300013-002
SCALE 1/1		DO NOT SCALE DWG. SHEET 1 OF 1		REV B

8 7 6 5 4 3 2 1

4

3

2

1

REVISIONS				
REV	DESCRIPTION	DATE	DR	CHK
A	RELEASE TO PROD. REF. E.O. 550075	11/18/72	MW	[Signature]

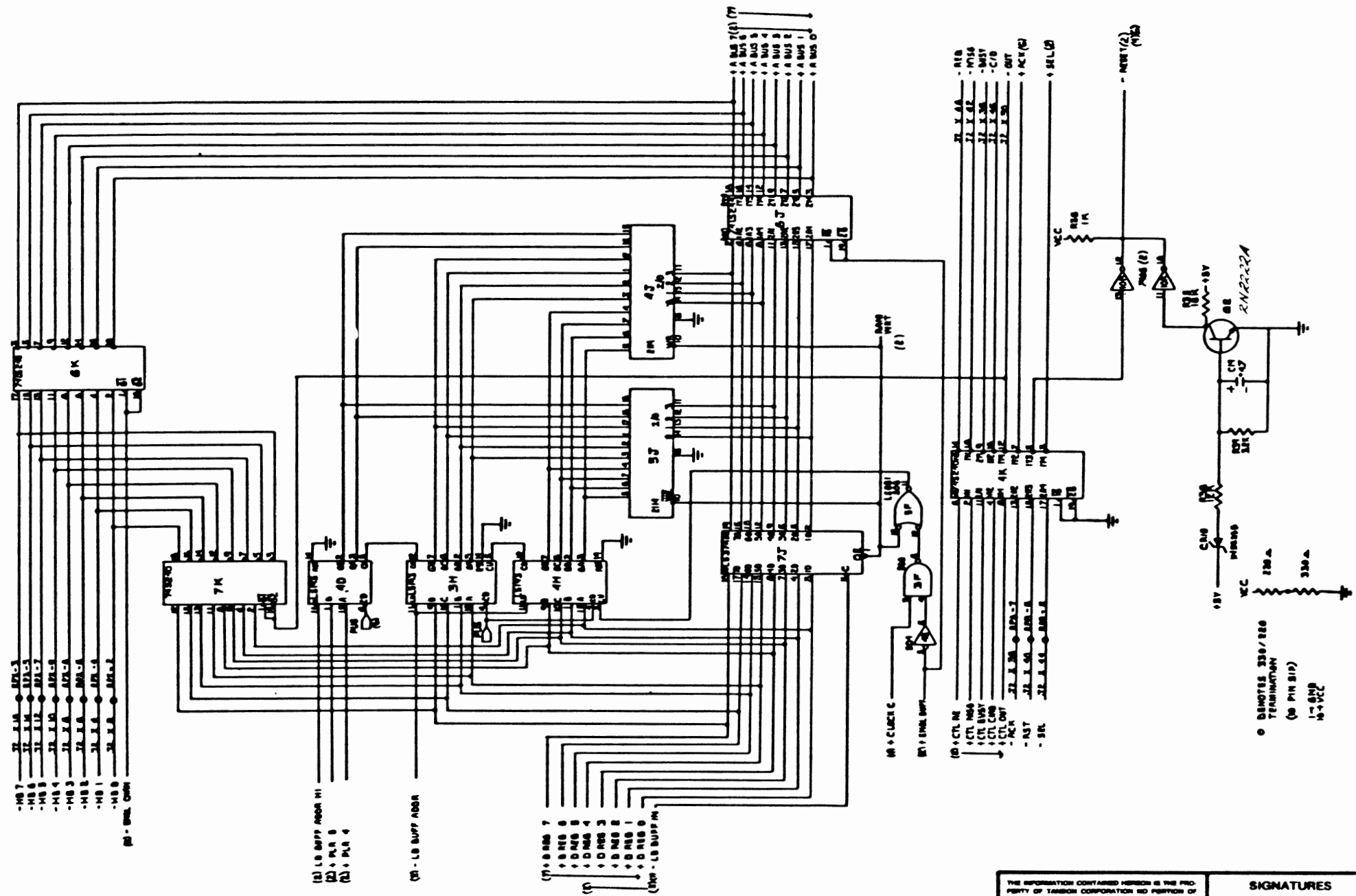

NOTES: UNLESS OTHERWISE SPECIFIED

<small>THE INFORMATION CONTAINED HEREIN IS THE PROPERTY OF TAYBORG CORPORATION AND PORTION OF THIS DATA SHALL BE RELEASED UNLESS OTHERWISE SPECIFIED FOR USE IN PRODUCTION OR MANUFACTURING WITHOUT SPECIFIC WRITTEN PERMISSION FROM TAYBORG CORPORATION.</small>		SIGNATURES DR: <i>M. Nove</i> DES: <i>M. Nove</i> PROJ ENGR: <i>R.W. Tanna</i>		DATE 11/18/72
<small>UNLESS OTHERWISE SPECIFIED DIMENSIONS ARE IN INCHES</small> TOLERANCES: XX ± XXI ± X ± ± BREAK ALL SHARP CORNERS APPROX. 90°		TITLE SCHEMATIC, 20A CONTROLLER		
FINISH:	MATL:	SIZE C	CODE IDENT NO. 180008-001	DWG NO. 180008-001
		SCALE NONE	DO NOT SCALE DWG	REV A
		SHEET 1 OF 7		

REVISIONS				
REV	DESCRIPTION	DATE	DR	CHK
	SEE SWT 1 OF 7			

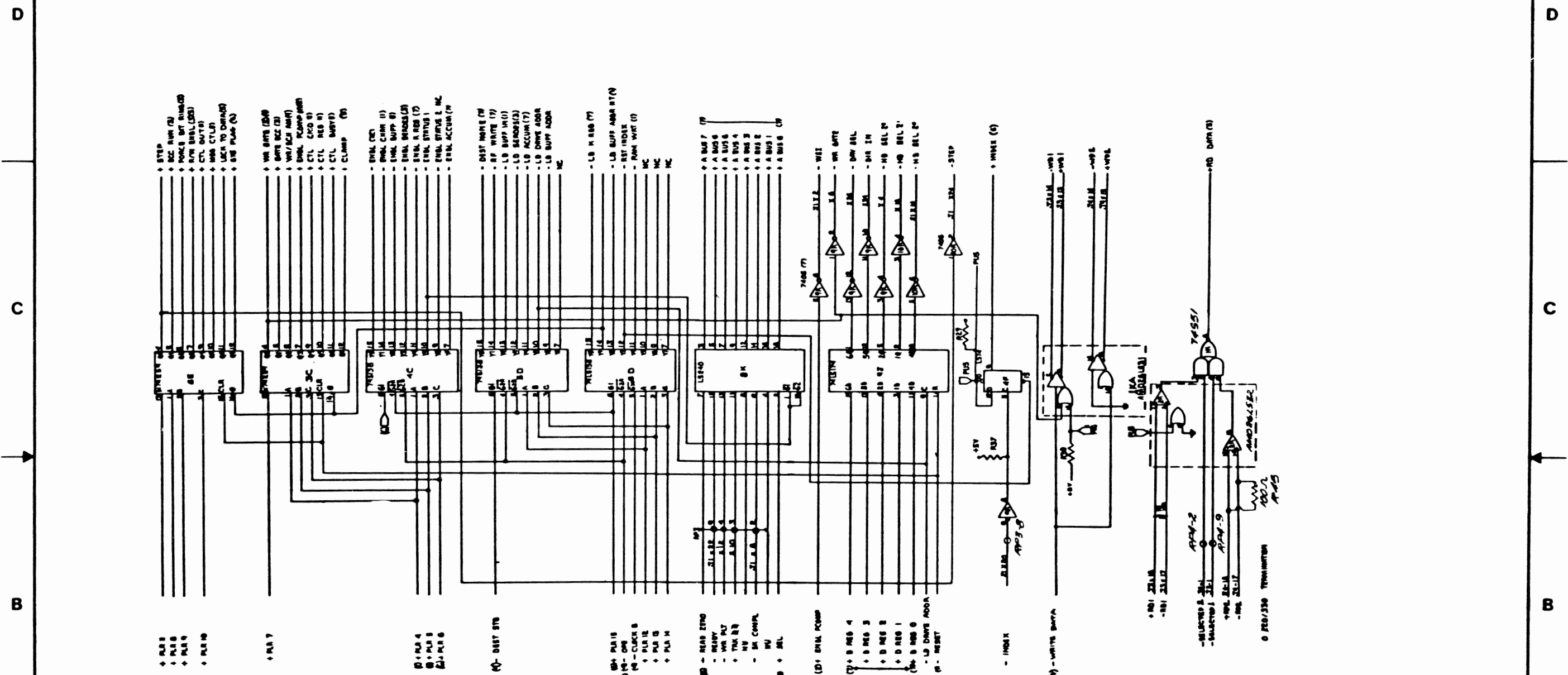

<p>UNLESS OTHERWISE SPECIFIED</p> <p>DIMENSIONS ARE IN INCHES</p> <p>TOLERANCES</p> <p>FRACTIONAL DECIMALS: ±</p> <p>ANGULAR: ± 1/2°</p> <p>BREAK ALL SHARP CORNERS APPROX 0.10</p>	<p>SIGNATURES</p> <p>DR</p> <p>CHK</p> <p>DES</p> <p>BRDR</p> <p>PRD/ BRDR</p>	<p>DATE</p>	<p>TITLE</p> <p>SCHEMATIC, 20A CONTROLLER</p>
	<p>FINISH</p>	<p>MATL</p>	

NOTES: UNLESS OTHERWISE SPECIFIED

REVISIONS				
REV	DESCRIPTION	DATE	DR	CHK
	SEE SMT 1 OF 7			

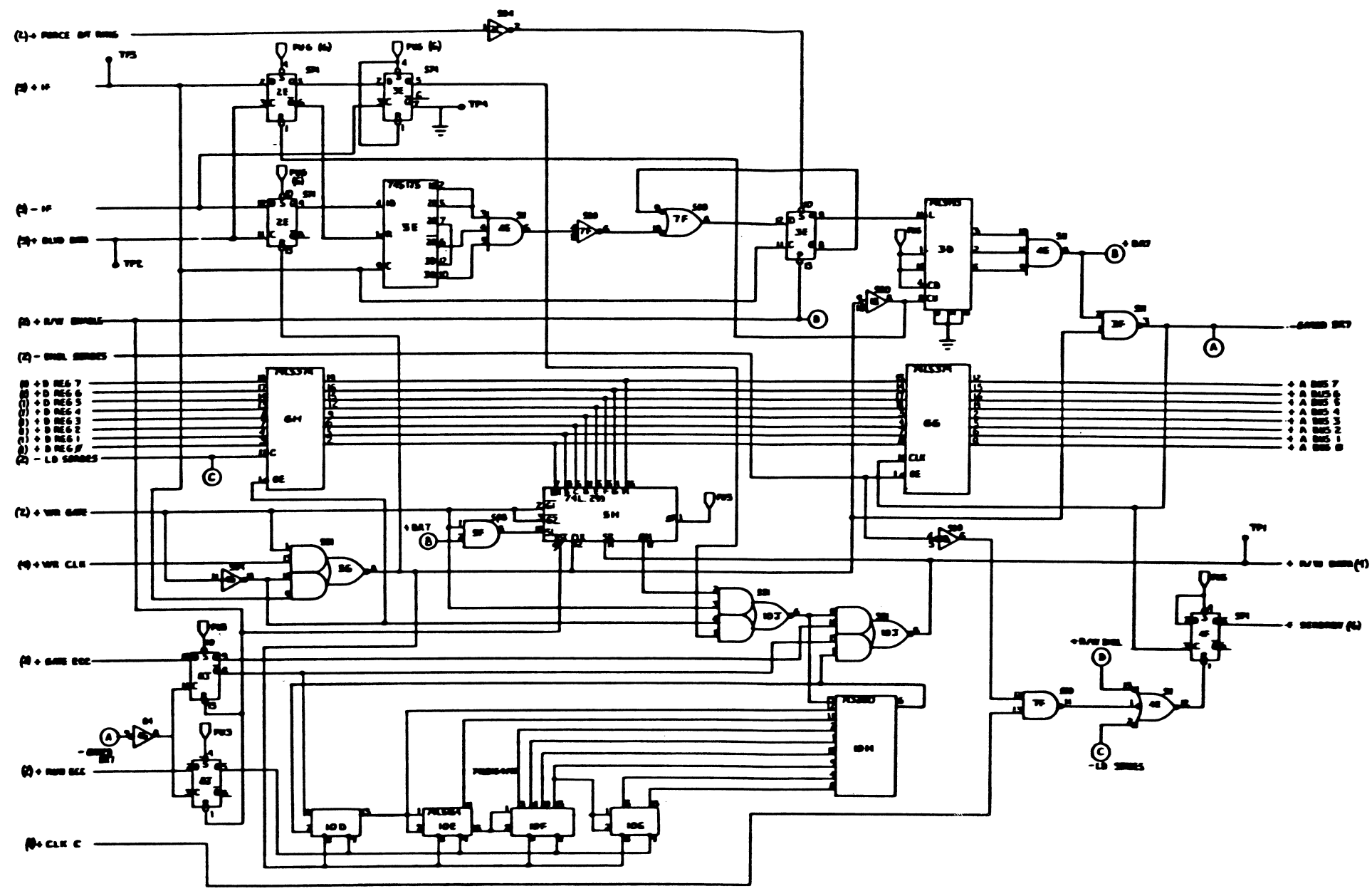

NOTES: UNLESS OTHERWISE SPECIFIED

<small>THE INFORMATION CONTAINED HEREIN IS THE PROPERTY OF TAYBORN CORPORATION AND PORTION OF THIS DATA SHALL BE RELEASED EXCEPT UNDER OR EMPLOYED FOR USE AS PRESCRIBED OR INDICATED BY TAYBORN CORPORATION WITHOUT SPECIFIC WRITTEN PERMISSION FROM TAYBORN CORPORATION.</small>	SIGNATURES		DATE	TITLE <h2 style="text-align: center;">SCHEMATIC, 20A CONTROLLER</h2>
	DR			
	CHK			
	DES			
<small>UNLESS OTHERWISE SPECIFIED DIMENSIONS ARE IN INCHES</small>	MATERIAL			
	FINISH:			
<small>TOLERANCES</small> XX ± .010 XXX ± .005 X ± .002 ± .001 <small>BREAK ALL SHARP CORNERS APPROX .040</small>	<small>ANGULAR</small> $\pm 1/2^\circ$	SIZE CODE IDENT NO. DWG NO. REV C 188008-001 A		
SCALE: AS SHOWN		DO NOT SCALE DWG SHEET 3 OF 7		

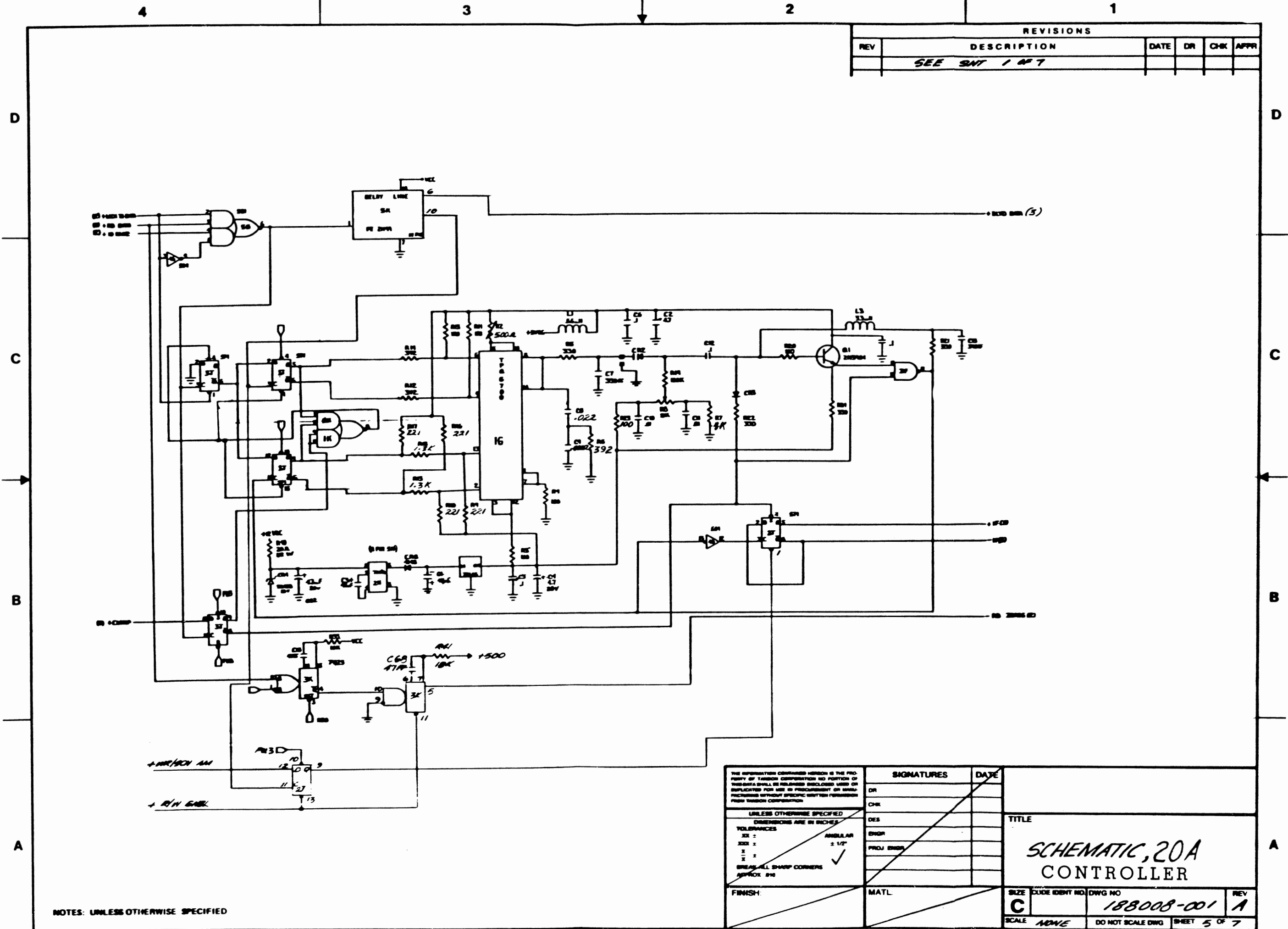

REVISIONS					
REV	DESCRIPTION	DATE	DR	CHK	APPR
	SEE SMT 1 OF 7				

NOTES: UNLESS OTHERWISE SPECIFIED

<small>THE INFORMATION CONTAINED HEREIN IS THE PROPERTY OF TAYLOR CORPORATION NO PORTION OF THIS DATA SHALL BE REPRODUCED, COPIED, OR REPLICATED FOR USE IN PROCUREMENT OR MANUFACTURING WITHOUT SPECIFIC WRITTEN PERMISSION FROM TAYLOR CORPORATION</small> <small>UNLESS OTHERWISE SPECIFIED DIMENSIONS ARE IN INCHES</small> <small>TOLERANCES</small> <small>XX ±</small> <small>XXX ±</small> <small>± 1/2"</small> <small>BREAK ALL SHARP CORNERS APPROX. 9/16</small> <small>FINISH:</small>	SIGNATURES		DATE	<small>TITLE</small> SCHEMATIC, 20A CONTROLLER
	DR			
	CHK			
	DES			
	ENGR			
PROJ ENGR				
MATL				
SIZE	EXCISE IDENT NO.	DWG NO.	REV	
C		188008-001	A	
SCALE	NONE	DO NOT SCALE DWG	SHEET	5 OF 7

REVISIONS					
REV	DESCRIPTION	DATE	DR	CHK	APPR
	SEE SH 1 OF 7				

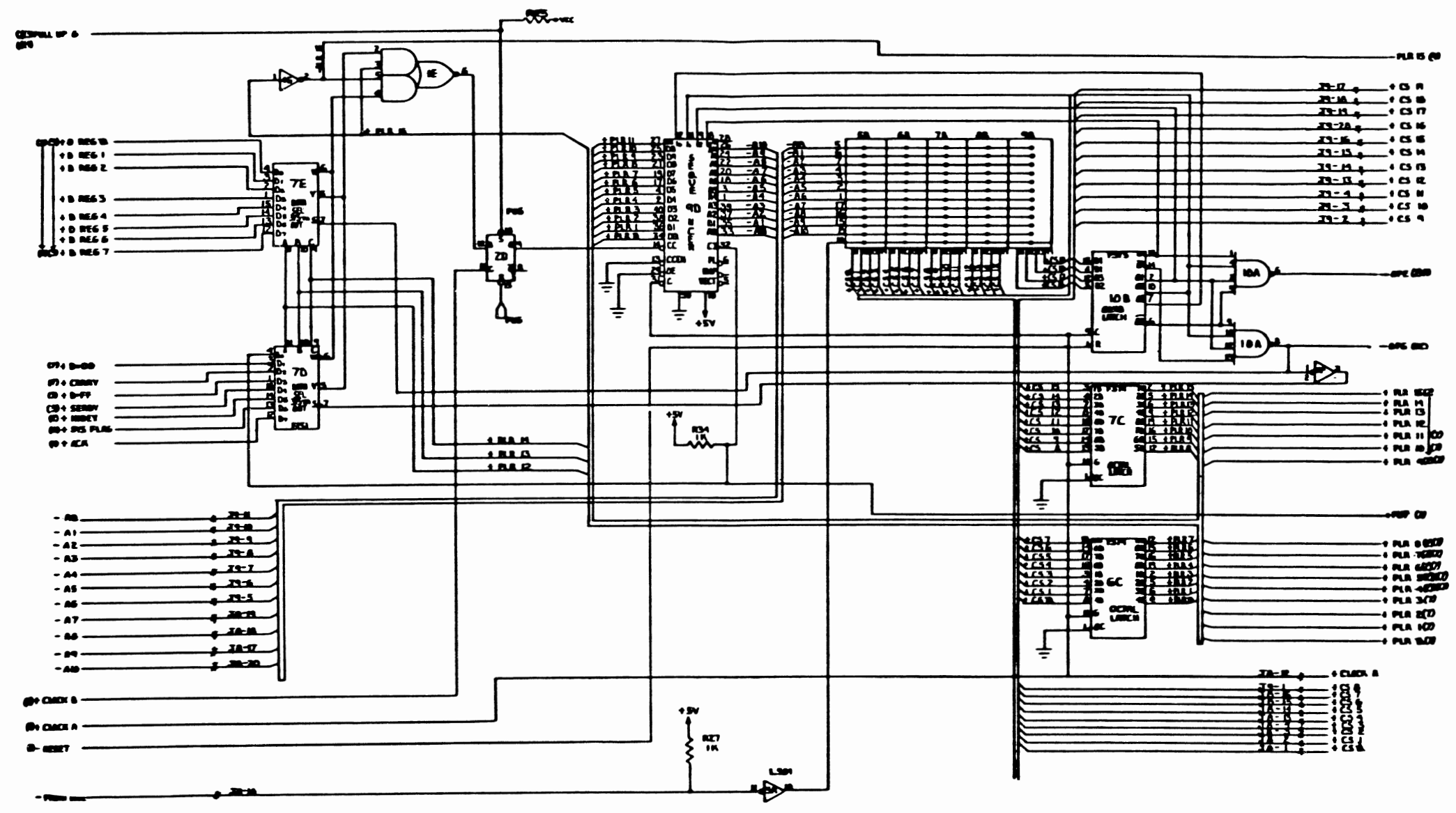

NOTES: UNLESS OTHERWISE SPECIFIED

<small>THE INFORMATION CONTAINED HEREIN IS THE PROPERTY OF THOMSON CORPORATION AND PORTION OF THIS DATA SHALL BE RELEASED UNLESS USE IS SPECIFICALLY FOR USE IN PRODUCTION OR MANUFACTURING WITHOUT SPECIFIC WRITTEN PERMISSION FROM THOMSON CORPORATION.</small>		SIGNATURES		DATE	
<small>UNLESS OTHERWISE SPECIFIED DIMENSIONS ARE IN INCHES</small>		DR	TITLE SCHEMATIC, 20A CONTROLLER		
<small>TOLERANCES</small> DEC ± ANGULAR ± 1/2°		CHK			
<small>BREAK ALL SHARP CORNERS APPROX 90°</small>		DES			
FINISH		ENGR			
		PROJ ENGR			
MATL		SIZE C		CODE IDENT NO. 188008-001	DWG NO. 1
		SCALE NONE		DO NOT SCALE DWG	REV 1
				SHEET 6 OF 7	

4

3

2

1

REVISIONS				
REV	DESCRIPTION	DATE	DR	CHK
	SEE DWT 1 OF 7			

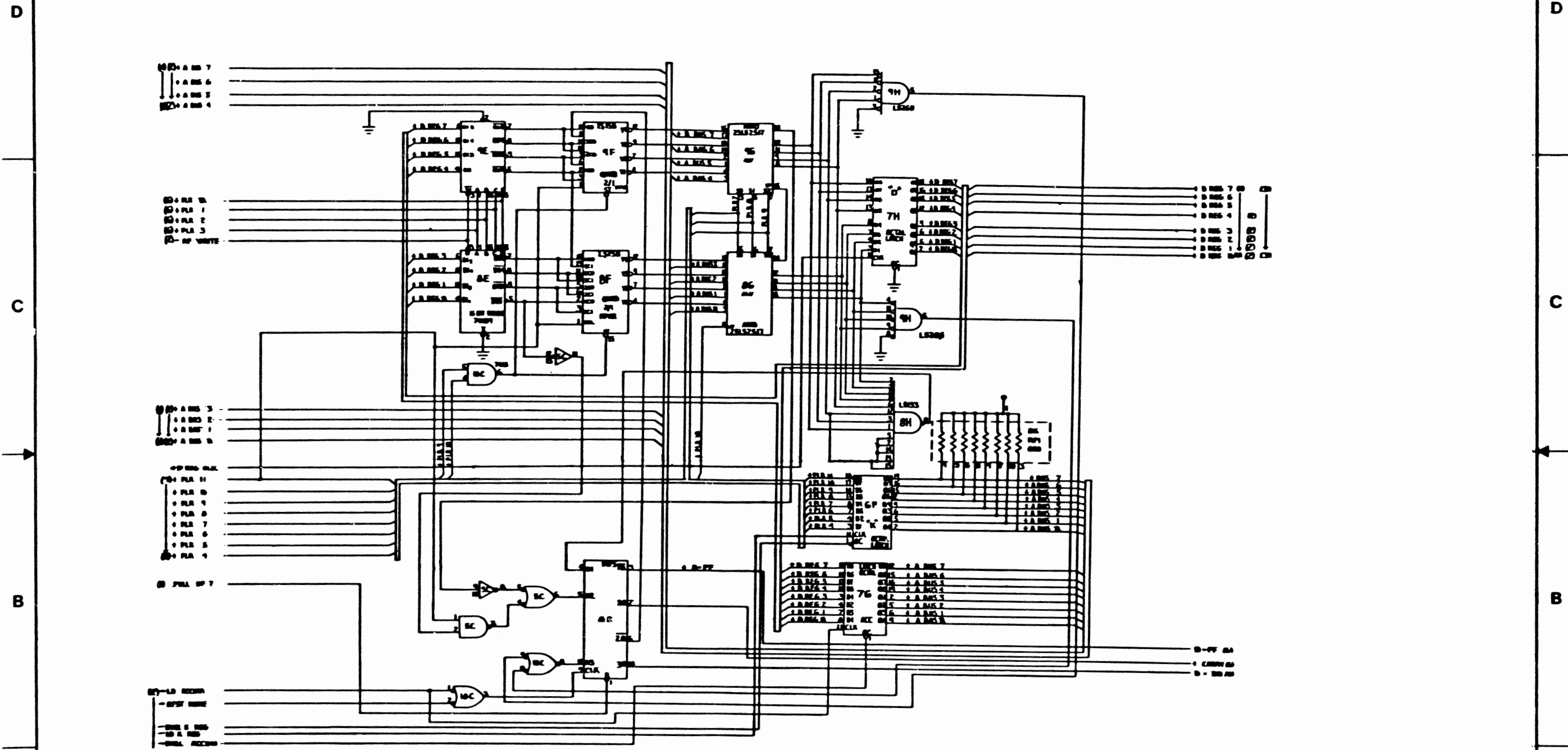

NOTES: UNLESS OTHERWISE SPECIFIED

<small>THE INFORMATION CONTAINED HEREIN IS THE PROPERTY OF THOMSON CORPORATION AND FORMER OF THE DATA SHALL BE RELEASED UNLESS USE IS AUTHORIZED FOR USE IN PROSECUTION OR INVESTIGATION WITHOUT SPECIFIC WRITTEN PERMISSION FROM THOMSON CORPORATION.</small>	SIGNATURES		DATE
	DR		
	CHK		
	DES		
<small>UNLESS OTHERWISE SPECIFIED DIMENSIONS ARE IN INCHES</small>	TITLE		
	<p style="text-align: center;">SCHEMATIC, 201 CONTROLLER</p>		
<small>TOLERANCES</small> X.XX ± X.X ± X ± X ±	<small>ANGULAR</small> ± 1/2° <input checked="" type="checkbox"/>	<small>FINISH:</small>	<small>MATL:</small>
<small>UNLESS OTHERWISE SPECIFIED DIMENSIONS ARE IN INCHES</small>		<small>SCALE</small> NONE	<small>DO NOT SCALE DRWG</small>
<small>SIZE</small> C	<small>CODE IDENT NO.</small> 188008-001	<small>DWG NO.</small> 188008-001	<small>REV</small> A
		<small>SHEET</small> 7 OF 7	

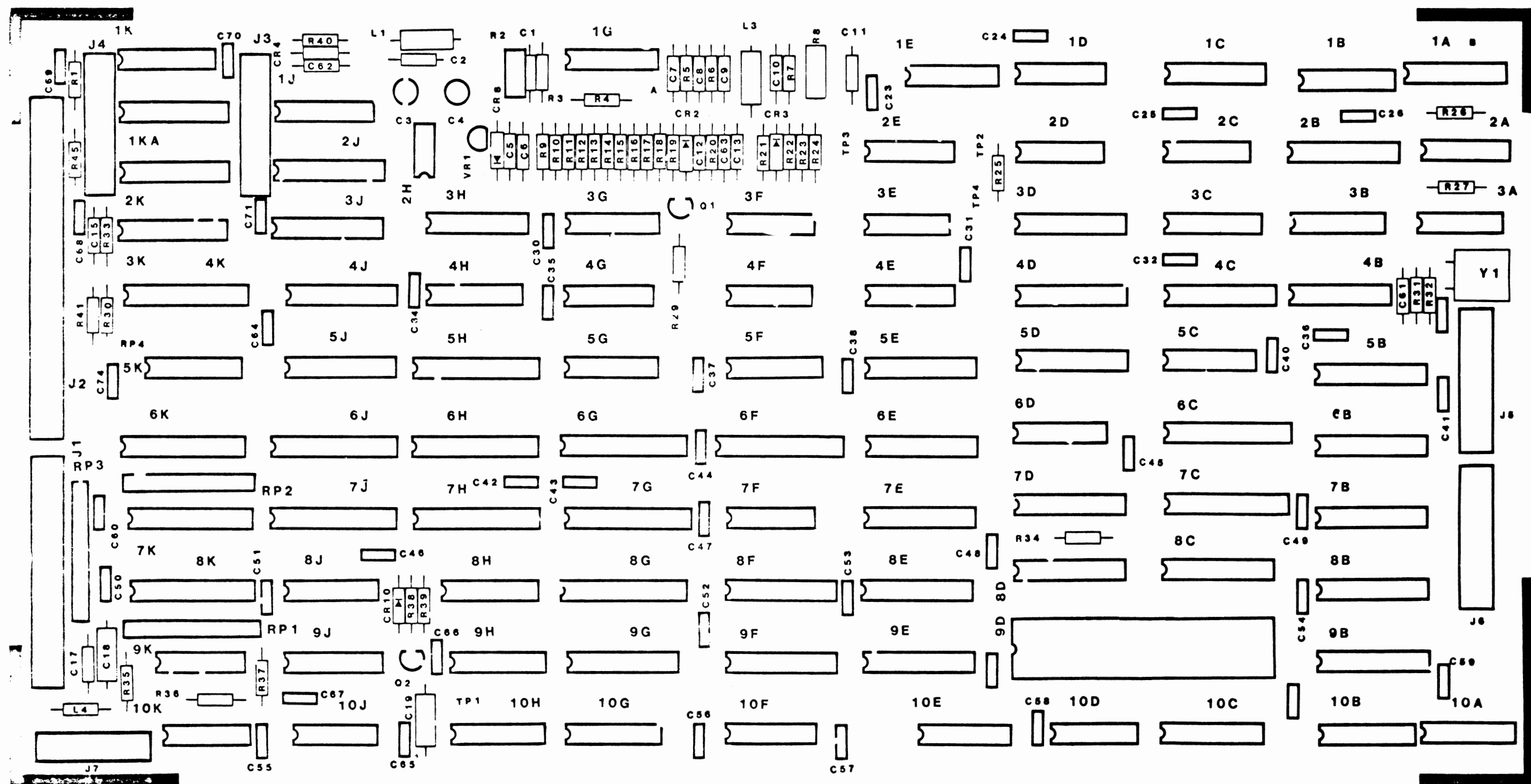

CONTROLLER PCBA

APPENDIX 1

803 Industry Dr
#23

MAJOR SUBASSEMBLIES

<u>Assembly Number</u>	<u>Type</u>	<u>Quantity</u>
300013-001	Disk Operating System (DOS) PCBA	1
188001-001	Control PCBA	1
300018-001	Power Supply, +5 and +12 volts D. C.	1
300507-001	Transformer Assembly	1
300508-001	Transformer, 117 volts, 100 volts A. C., 50-60 Hertz	1
187002-001	602S Drive	1
187002-002	603S Drive	1

APPENDIX 2

RECOMMENDED SPARE PARTS LIST

The following spare parts are available from the Voyager Systems Division of Tandon Corporation.

<u>Part Number</u>	<u>Description</u>
187045-001	Control and Data PCBA
187065-001	Spindle Control PCBA
187010-001	Index Assembly
187021-001	Track 00 Optical Assembly
187021-001	Frame Assembly
188001-001	Control PCBA
300018-001	Power Supply
300013-001	DOS PCBA
300508-001	Transformer, 117 volts
300508-002	Transformer, 220 volts
187002-001	TM602S Drive
187002-002	TM603S Drive

APPENDIX 3

<u>Drawing Number</u>	<u>Title</u>	<u>Number of Sheets</u>
300520-00X	Commodore Disk System Expanded View	2
300010-002	Winchester DOS/Controller Schematic	3
300013-002	Winchester DOS/Controller PCB Assembly	1
188008-001	Disk Drive Controller Schematic	7
	Disk Drive Controller PCB Assembly	1
187040-001	TM600 Control and Data Schematic	2
187045-001	TM600 Control and Data PCB Assembly	1
187060-001	TM600 Spindle Control Schematic	1
187065-001	TM600 Spindle Control PCB Assembly	1
300015-001	Power Supply Schematic	1
	Addendum To 300015-001 Fold Back Circuit	1
300018-001	Power Supply PCB Assembly	1

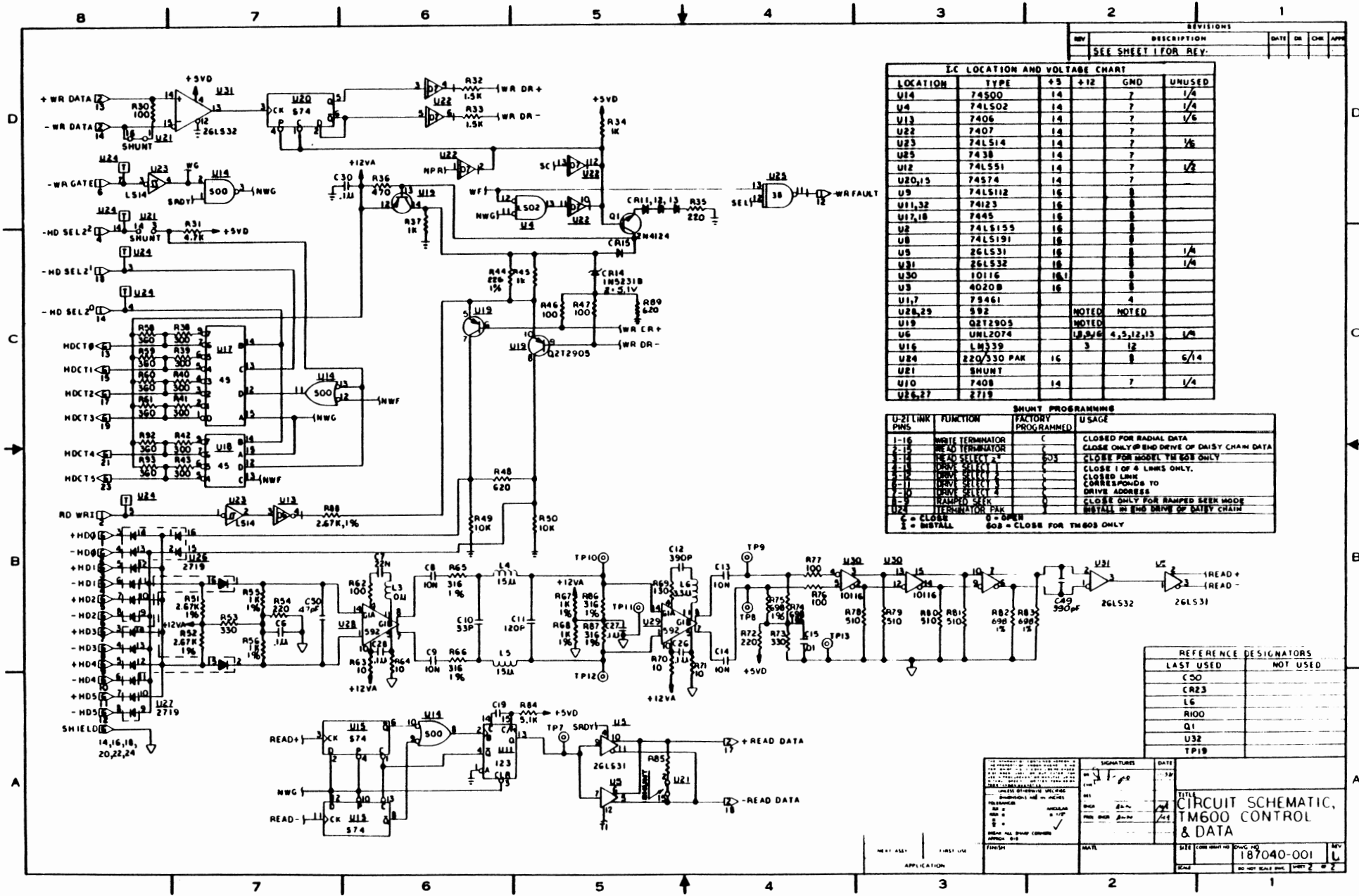

REVISIONS		DATE	BY	CHK	APP
B	REV PER E.O. 33000	11/15/77
C	REV PER E.O. 33007
D	REV PER E.O. 33013
E	REV PER E.O. 33017
F	REV PER E.O. 33007
G	REV PER E.O. 330016
J	REV PER E.O. 330092
K	REV PER E.O. 330120
L	REV PER E.O. 330156
M	REV PER E.O. 330167

DESIGNATOR ASSEMBLY GUIDE		
LAST USED	REV	DATE
C48	C19	C18-BUS2
C82A	C81Q	
J4		L3-05
D1		
R100	R17,685	
TP1Q		
U32		

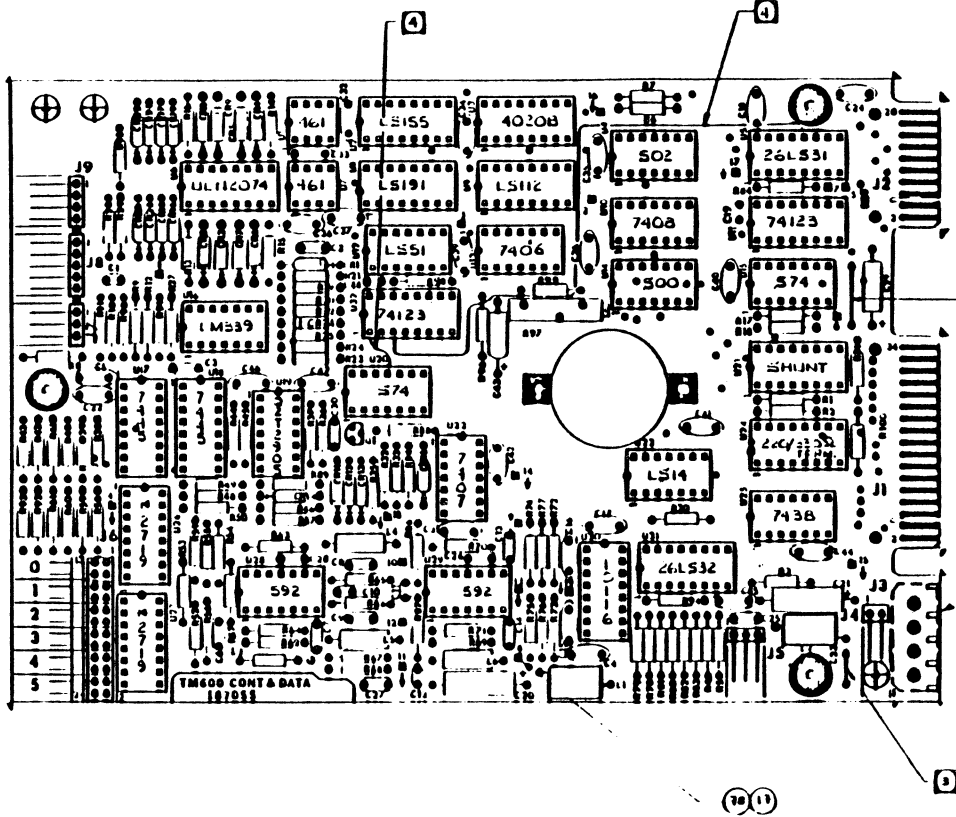

J3 MOUNTS ON FARSIDE

- 3 Jumper PER E.O. 33000
 - 4 Jumper PER E.O. 330024
 - 11 SOLDER T24 AND UNINSULATED TIN COATED SOLID COPPER WIRE. MAY SUBSTITUTE 14W RESISTOR LEAD WIRE.
2. REF DOCUMENT: 187040-001 - CIRCUIT SCHEMATIC
187042-001 - ARTWORK
1. SEE SHEET 1 THRU 3 FOR PART LIST

		TITLE ASSEMBLY, TM600 CONTROL & DATA
DATE 8/71	REV 1	PART NO 187045-001

ADDENDUM TO DRAWING NUMBER 300015-001, FOLD BACK CIRCUIT

Values for earlier revisions up to and including Revision G are:

$$\begin{aligned}\Delta R12 &= 390 \Omega \\ \Delta R3 &= 75 \Omega \\ \Delta R13 &= 12 \Omega\end{aligned}$$

Value for earlier revisions up to and including Revision H:

$$\Delta R4 = 3.9 \Omega$$

Changes are not mandatory.

This information is provided for reference only.

REVISIONS					
REV	DESCRIPTION	DATE	DR	CHK	APP
B	REV PER E.O. 11539	1/24/74	MAJ		AW
C	REV PER E.O. 11558	1/24/74	MAJ		AW
D	REV PER E.O. 53006	1/24/74	MAJ		AW
E	REV PER E.O. 53043	1/24/74	MAJ		AW

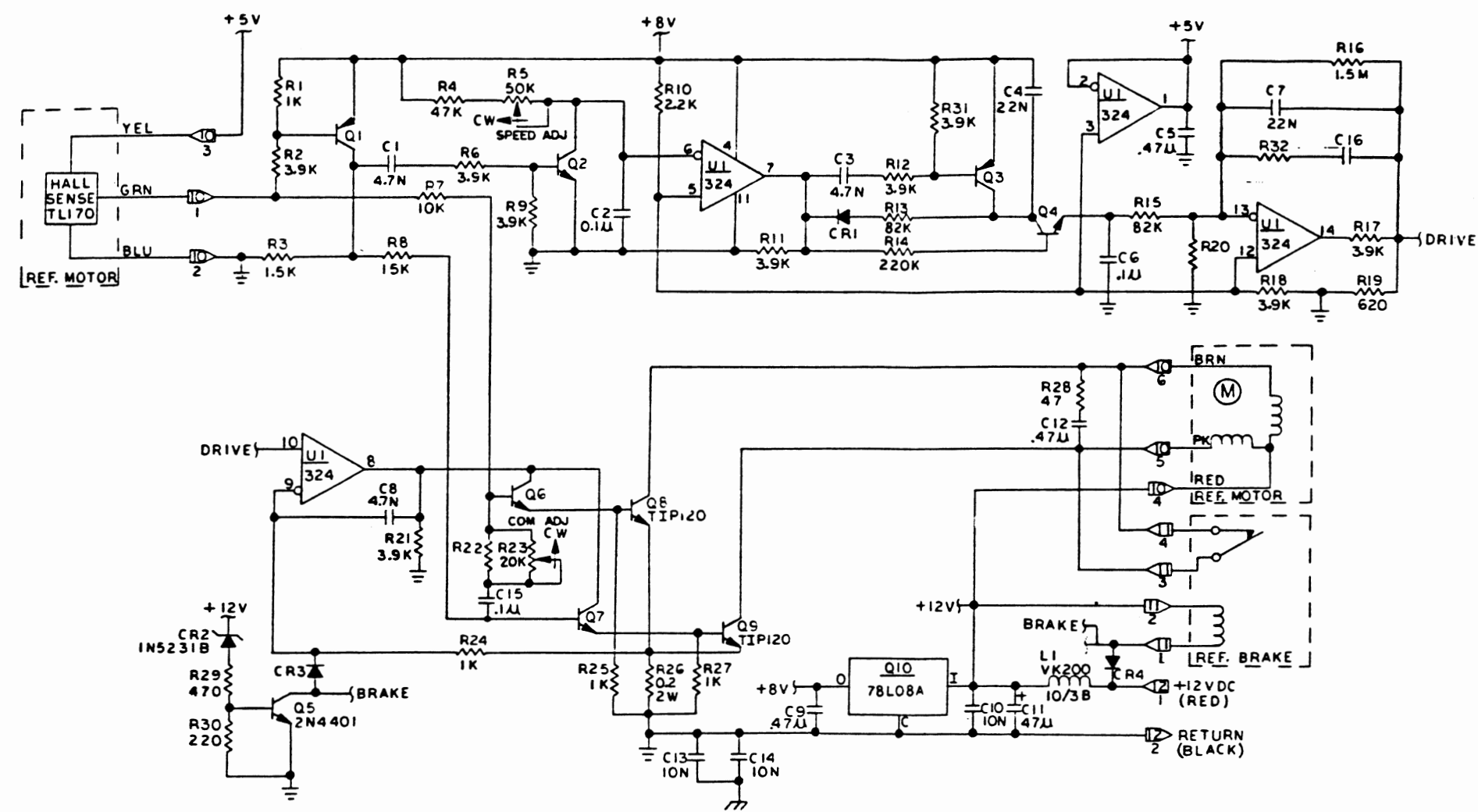

7. UNVALUED COMPONENTS ARE OMITTED.
 X <X>
 A. G. Y OR Y DENOTES CONNECTOR X, PIN Y.
 5. PNP TRANSISTORS ARE 2N4125.
 4. NPN TRANSISTORS ARE 2N4124.
 3. DIODES ARE IN4446 OR EQUIV.
 2. CAPACITORS ARE 25V, 10%, PF, NF, OR MF.
 1. RESISTORS ARE IN OHMS, 1/4W, 5%.

NOTES: UNLESS OTHERWISE SPECIFIED

REFERENCE DESIGNATORS	
LAST USED	NOT USED
C16	
CR4	
J3	
L1	
Q10	
R32	
U1	

SIGNATURES		DATE
DR: <i>[Signature]</i>		2381
CHK: <i>[Signature]</i>		
TITLE		
CIRCUIT SCHEMATIC, TM600 SPINDLE CONTROL		
SIZE	CODE	REV. NO.
D		187060-001 E
SCALE	N/O N/B	DO NOT SCALE DIMS. UNLESS SPECIFIED

NEXT ASSY	FIRST USE
APPLICATION	

8 7 6 5 4 3 2 1

REVISIONS					
REV	DESCRIPTION	DATE	DR	CHK	APP
B	REV PER EC # 11533	11-2-61	MB	MB	MB
C	REV PER EC # 11561	11-2-61	MB	MB	MB
D	REV PER E.O. S30006	1-10-61	MB	MB	MB
E	REV PER E.O. S30043	9-28-61	MB	MB	MB
F	REV PER E.O. S30201	4-2-62	MB	MB	MB

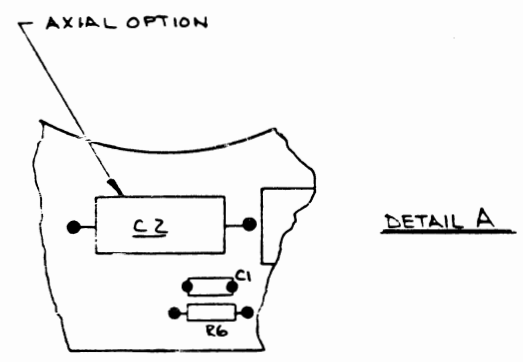
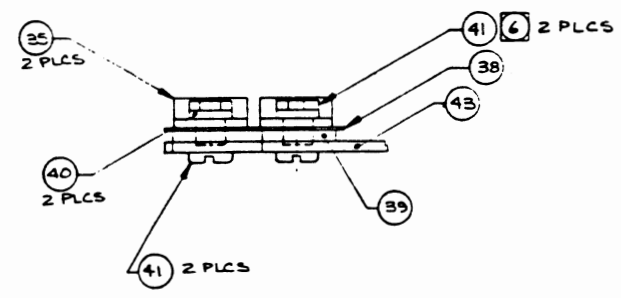
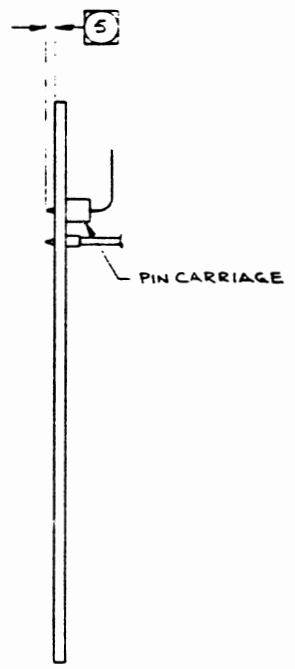
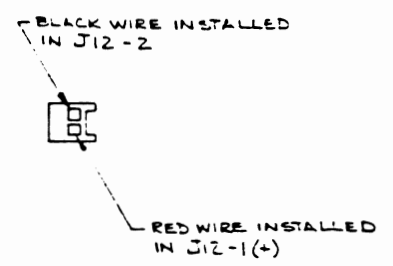
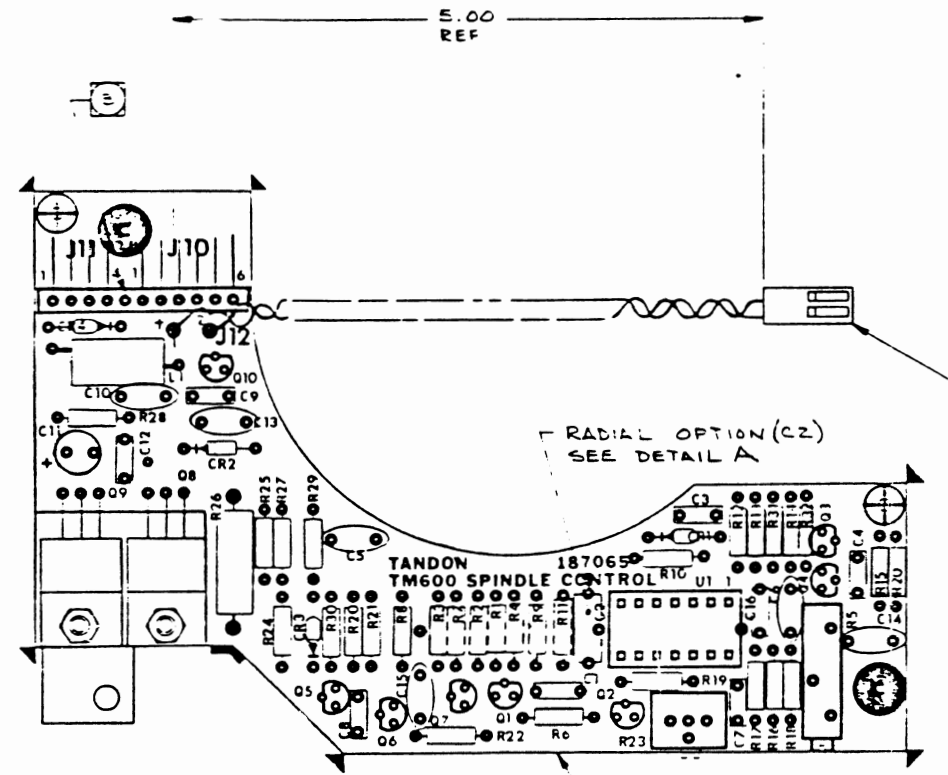

7. REF DOCUMENT : 187060-001 - CIRCUIT SCHEMATIC
187061-001 - ARTWORK

- 6 TORQUE 4.5 INCH LBS. NOMINAL.
 - 5 MAX LENGTH OF COMPONENT LEADS BELOW SOLDER SIDE BOARD AFTER ASSEMBLY & TRIMMING SHALL NOT EXCEED .08 INCH.
 - 4 COMPONENT HEIGHT, EXCEPT C11, SHALL NOT EXCEED .745 INCH ABOVE BOARD. CAPACITOR, C11, NOT TO EXCEED .50 INCH ABOVE BOARD.
 - 3 CUT PIN TANGENT TO PIN CARRIAGE.
 - 2 THIS ASSEMBLY SHALL BE MADE FROM P.C.B DETAIL 187060-001
1. ASSEMBLY PER STANDARD MANUFACTURING METHODS.

NOTES : UNLESS OTHERWISE SPECIFIED

USED ON TM600

TOLERANCES: DECIMALS: .015 INCHES ANGULAR: .12° HOLE: .005 INCHES BREAK ALL SHARP CORNERS! APPROX. DIM.		SIGNATURES: _____ DATE: _____ DR: _____ ENGR: _____ PRO: ENGR _____ FINISH: _____ MATL: _____		TITLE: SPINDLE CONTROL ASSY TM600	
SIZE: D	COORDINATE: 187065-001	DWG NO:	REV: F	SCALE: 1:1 DO NOT SCALE DIMS SHEET 3 OF 3	

8 7 6 5 4 3 2 1

REVISIONS					
REV	DESCRIPTION	DATE	DR	CHK	APP
B	REDESIGNED	1-81			
C	RELEASE TO PROD PER E.O.#530215	3-81			
D	REVISED PER E.O.#530249	4-7-81			
E	REVISED PER E.O. 550012	7-14-81			
F	REVISED PER E.O. 550044	7-21-81			
G	REVISED PER E.O. 550073	7-24-81			
H	REVISED PER E.O. 350060	7-25-81			
J	REVISED PER E.O. 350073B	7-16-81			

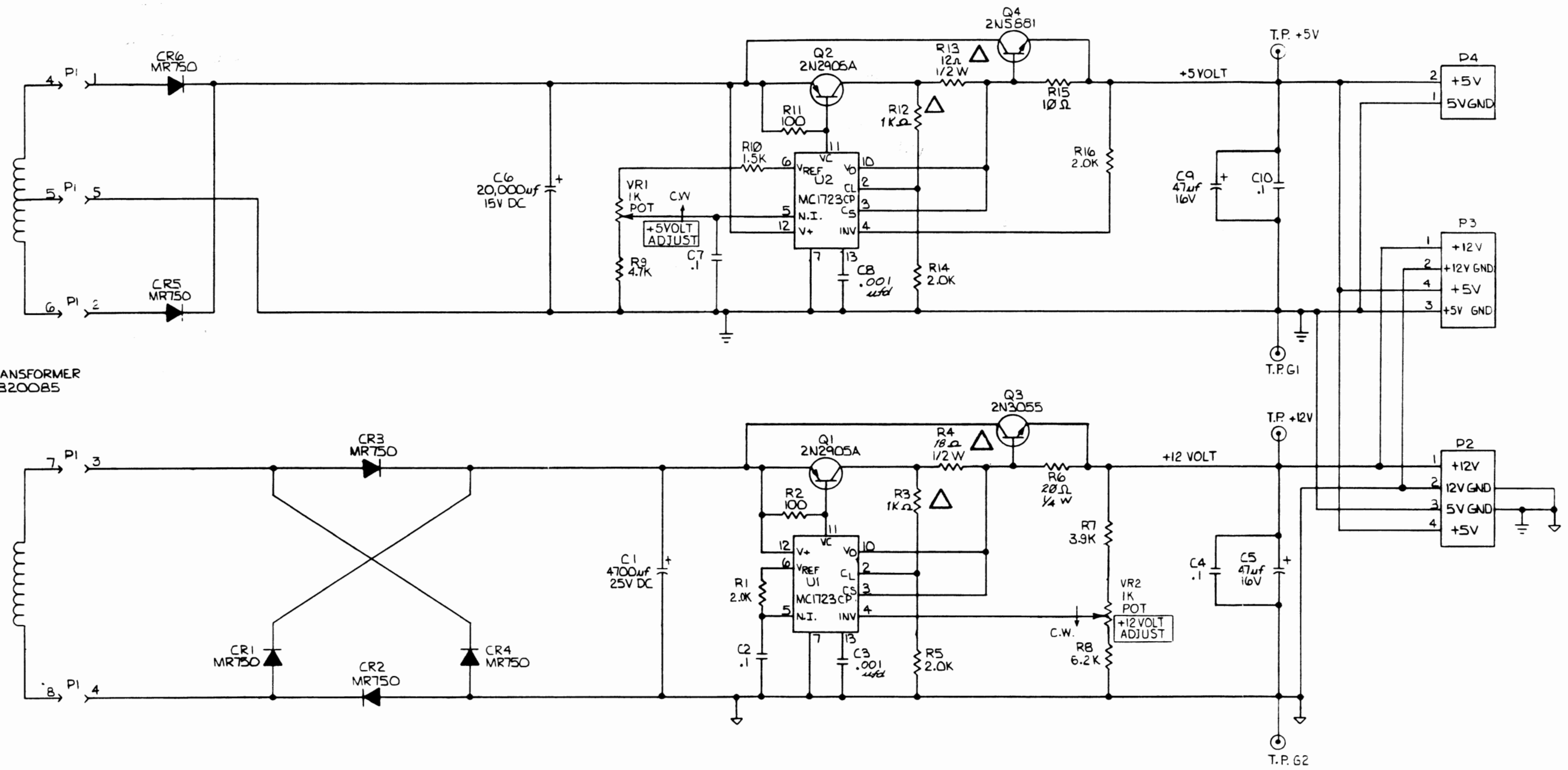

△ SEE FOLD BACK CIRCUIT

NOTE: ACROSS R3 AND R12 WHEN THEY ARE 1KΩ SELECT IN TEST. RESISTOR PLACED IN PARALLEL.

NOTES: UNLESS OTHERWISE SPECIFIED

<small>THE INFORMATION CONTAINED HEREON IS THE PROPERTY OF RANDOLPH MAGNETICS AND NO PORTION OF THIS DATA SHALL BE REPRODUCED, DISCLOSED, USED, OR DUPLICATED FOR USE IN PROCUREMENT OR MANUFACTURING WITHOUT SPECIFIC WRITTEN PERMISSION FROM RANDOLPH MAGNETICS.</small>		SIGNATURES DR. RICHMAR DATE: 9-81	
<small>UNLESS OTHERWISE SPECIFIED DIMENSIONS ARE IN INCHES</small>		TITLE PCB SCHEMATIC POWER SUPPLY WINCHESTER CONTROLLER	
<small>TOLERANCES: .XXX ± .001 .XX ± .002 .X ± .005 BREAK ALL SHARP CORNERS APPROX. .010</small>		SIZE CODE IDENT NO. DATE NO. D 300015-001	
NEXT ASSY FIRST USE APPLICATION		MATL. FINISH. SCALE NONE DO NOT SCALE DIM. SHEET 1 OF 1	

8 7 6 5 4 3 2 1

REVISIONS					
REV	DESCRIPTION	DATE	DR	CHK	APP
B	RELEASE TO PROD PER E.O. #530214	5-8-81	CR		DM
C	REVISED PER E.O. 530214	5/14/81	CR		DM
D	REVISED PER E.O. 530000	5/14/81	CR		DM
E	REVISED PER E.O. 530012	7/14/81	CR		DM
F	REVISED PER E.O. 530044	8/14/81	CR		DM

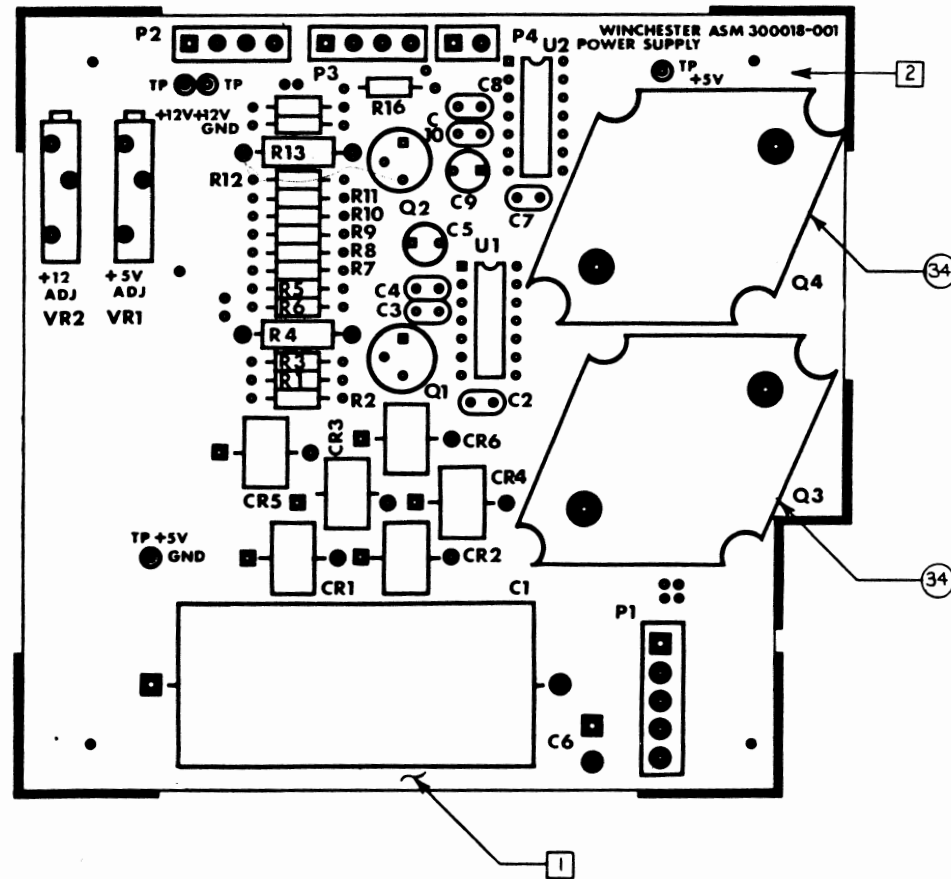

NOTES: UNLESS OTHERWISE SPECIFIED

<small>THE INFORMATION CONTAINED HEREIN IS THE PROPERTY OF ARCON MANUFACTURING COMPANY. IT IS TO BE KEPT UNCLASSIFIED FOR USE IN PRODUCTION OF MANUFACTURING MATERIALS SPECIFICALLY IDENTIFIED FROM ARCON MANUFACTURING COMPANY.</small>	SIGNATURES	DATE	TITLE PCB ASSEMBLY POWER SUPPLY WINCHESTER CONTROLLER
	DR RICHMAR	2-8-81	
	DES		
	ENGR		
DIMENSIONS: ALL IN INCHES TOLERANCES: .XXX ± .XXX ± .X ± .X ± BREAK ALL SHARP CORNERS APPROX .010	ANGULAR ± 1/2° ✓		
NEXT ASSY FIRST USE APPLICATION	FINISH MATL	SIZE D CODE IDENT NO SCALE 2/1	DWG NO 300018-001 DO NOT SCALE DWG
			REV 1

7 6 5 4 3 2 1