Commodore
Word Processor Printer

User's Manual

Model 6400



 **commodore**
COMPUTER

Commodore
Word Processor Printer

User's Manual

Model 6400

Part Number 251335

Second edition: May 1983
Copyright © 1983 by Commodore Business Machines, Inc.
All rights reserved.

This manual is copyrighted and contains proprietary information. No part of this publication may be reproduced, stored in a retrieval system, or transmitted in any form or by any means, electronic, mechanical, photocopying, recording or otherwise, without the prior written permission of COMMODORE BUSINESS MACHINES, Inc.

CONTENTS

1. INTRODUCTION	3
1-1. General Description	3
1-2. Basic Specifications	4
1-3. Exterior View and Nomenclature	5
2. PREPARATIONS FOR USE	6
2-1. Unpacking Instructions	6
2-2. Installation	7
2-3. Pre-operation Checks	8
2-4. Control Panel	9
2-5. Paper Insertion	9
2-6. Print Alignment	10
2-7. Ribbon Cartridge Replacement	10
2-8. Print Wheel Replacement	11
2-9. Automatic Self-Test	13
2-10. Periodic Maintenance	13
3. OPERATING/ALERT SWITCHES AND INDICATOR LAMPS	18
3-1. Operating Switches	18
3-2. Alert Switches	19
3-3. Indicator Lamps	20
4. IEEE-488 INTERFACE SPECIFICATION	20
4-1. IEEE Connector Pin Diagram	20
4-2. Signal Lines	21
4-3. Change of the Device Number	21
5. DIP SWITCH FUNCTIONS	22
5-1. DIP Switches	22
5-2. Examples of DIP Switch Setting	26
6. STANDARD CONTROL COMMANDS	27
7. ESC EXPANSION COMMANDS	29
7-1. Description of Command	29
7-2. Word Processing Functions	31
8. TABLES	34
8-1. PS Carriage Movement Data	34
8-2. Program Mode Hammer Energy Data	35
8-3. Character Code Table	36
8-4. Print Wheel Layout Drawing	37
9. SAMPLE PROGRAM	38
1. Horizontal Tab	38
2. Set Left Margin	39
3. Set Lines per Pages & etc.	40
4. Backward Print, Forward Print	42
5. Negative Line Feed	43

6.	Half Line Feed	44
7.	HMI, VHI	45
8.	Absolute Vertical Tab	46
9.	ESC Y, ESC Z	47
10.	Bi-directional Printing	48
11.	Proportional Space	49
12.	Offset Selection	50
13.	Underscore	51
14.	Bold, Shadow Print	52
15.	Carriage Settling Time	53
16.	Program Mode	54
17.	Cancel All WP Modes	55
18.	Backspace 1/120	56
19.	Back Space	57
20.	Carriage Return, Carriage Stand, Space	58

1. INTRODUCTION

1-1. General Description

This daisy wheel printer Model 6400 is designed for applications requiring high-quality printing. By employing CPU 8085 to perform all controls, it has become possible to make vast reductions in the number of electronic parts, improving reliability. The number of mechanical parts has also been reduced and serviceability greatly simplified. In addition, the following features have been incorporated:

- (1) Precision print wheel control has been achieved by means of a transducer, providing outstanding print quality.
- (2) An integral-constructed frame made by aluminum diecast assures improved maintenance.
- (3) Automatic Self-Test allows for quick and simple detection of printer trouble.
- (4) Automatic print pressure control prolongs print wheel life by varying the printing pressure according to character shape.
- (5) Paper Out detects the paper end, interrupts print operation and lights up the control panel.
- (6) Both serial and line modes are switch-selectable.

1-2. Basic Specifications

(1)	Printing speed (ch/sec.)	40 CPS									
(2)	Printing system	Static font impact system									
(3)	Number of columns	136 (Pica pitch) 163 (Elite pitch)									
(4)	Print spacing (min.)	1/120 inches									
(5)	Line feed spacing (min.)	1/48 inches									
(6)	Carriage return	900 ms									
(7)	Line feed speed	40 ms (1/6 inches)									
(8)	Paper width	420 mm (Print Aria 13.6 inches)									
(9)	Number of copies	Original plus 2 copies (0.2 mm thick)									
(10)	Ink ribbon	Cartridge type 8 mm wide, 16 mm long Color: Black									
(11)	Number of character types	96									
(12)	Font	Courier 10									
(13)	Interface	IEEE 488									
(14)	Power Source	180-254 V, 90-127 V (at 50/60 Hz)									
(15)	Ambient conditions	<table border="0"> <tr> <td></td> <td>Temperature</td> <td>Humidity</td> </tr> <tr> <td>Operating</td> <td>5-36°C</td> <td>10-90% (RH)</td> </tr> <tr> <td>Storage</td> <td>-25-60°C</td> <td>2-98% (RH)</td> </tr> </table>		Temperature	Humidity	Operating	5-36°C	10-90% (RH)	Storage	-25-60°C	2-98% (RH)
	Temperature	Humidity									
Operating	5-36°C	10-90% (RH)									
Storage	-25-60°C	2-98% (RH)									
(16)	Noise	Lower than 65 dB (A) (1 meter distant from platen front)									
(17)	Weight	14 kg									

1-3. Exterior View and Nomenclature

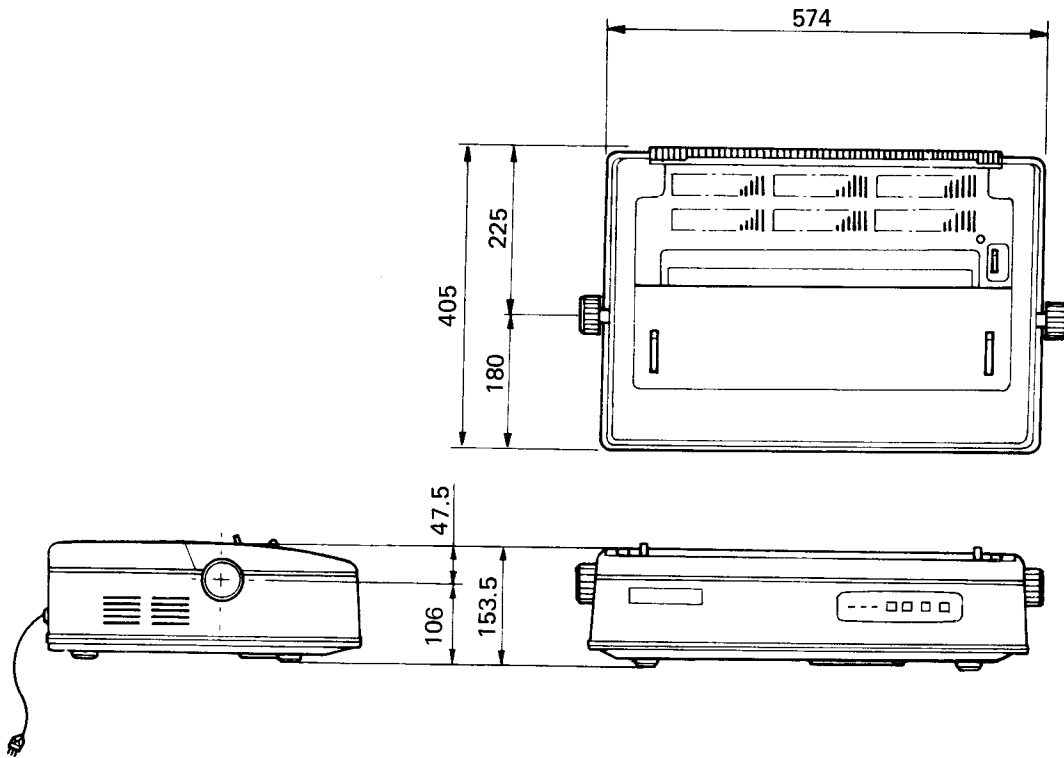
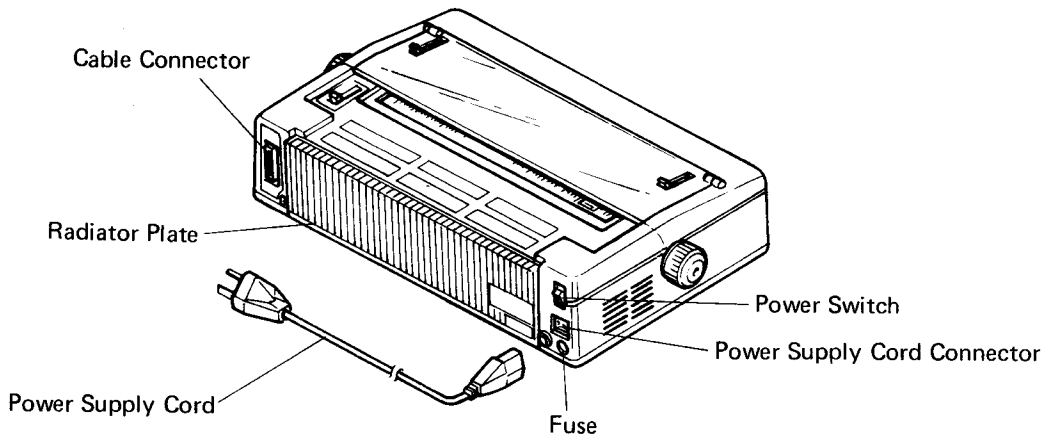
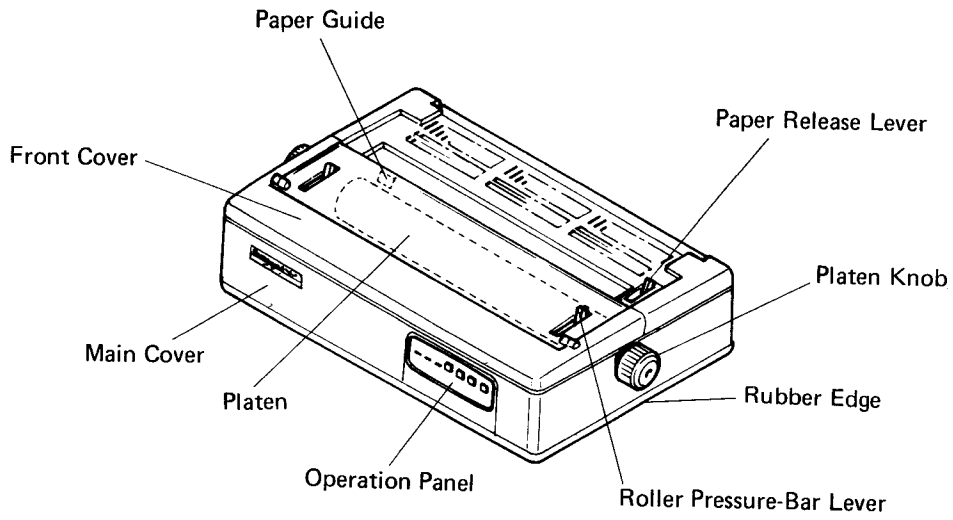

2. PREPARATIONS FOR USE

2-1. Unpacking Instructions

- (1) First, slit the tape holding the top flaps closed. Be careful not to damage the unit with sharp blades.
- (2) Take the ribbon cassette and print wheel out of the wells in the top pad. Then remove the top pad slowly with both hands from the outer carton. See Fig. A.

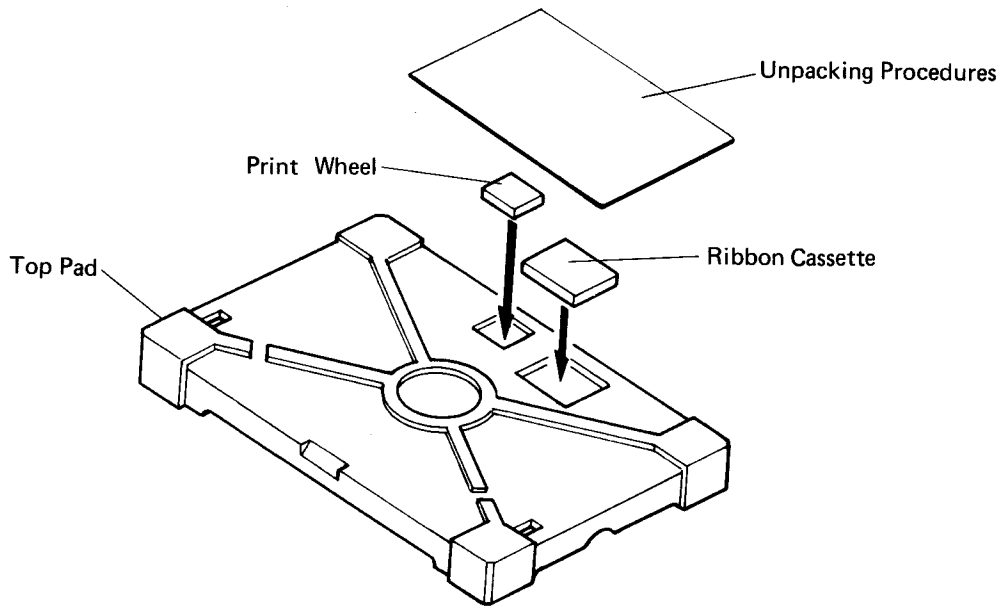

Figure A

- (3) Remove the user's manual on the printer and the power supply cord behind the heat sink. See Fig. B.

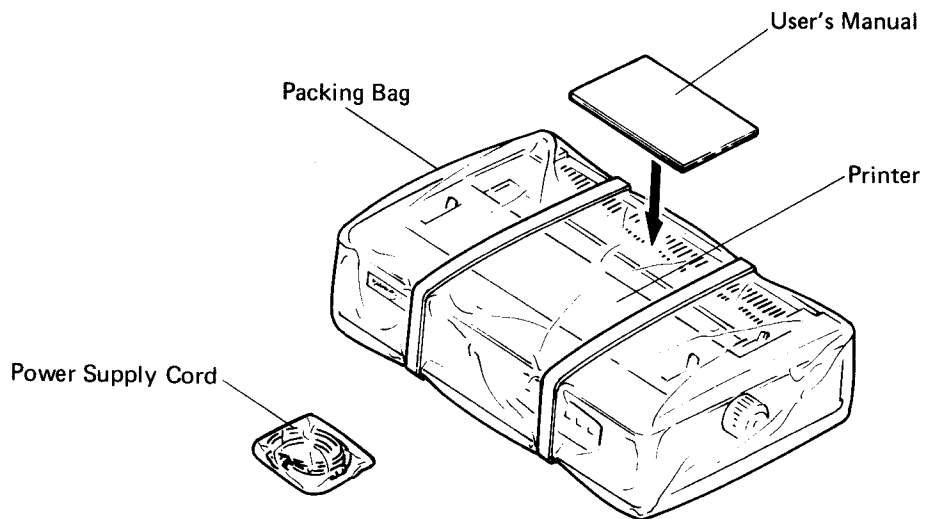

Figure B

(4) Draw out the printer slowly by pulling the bands to retain the printer with both hands. See Fig. C.

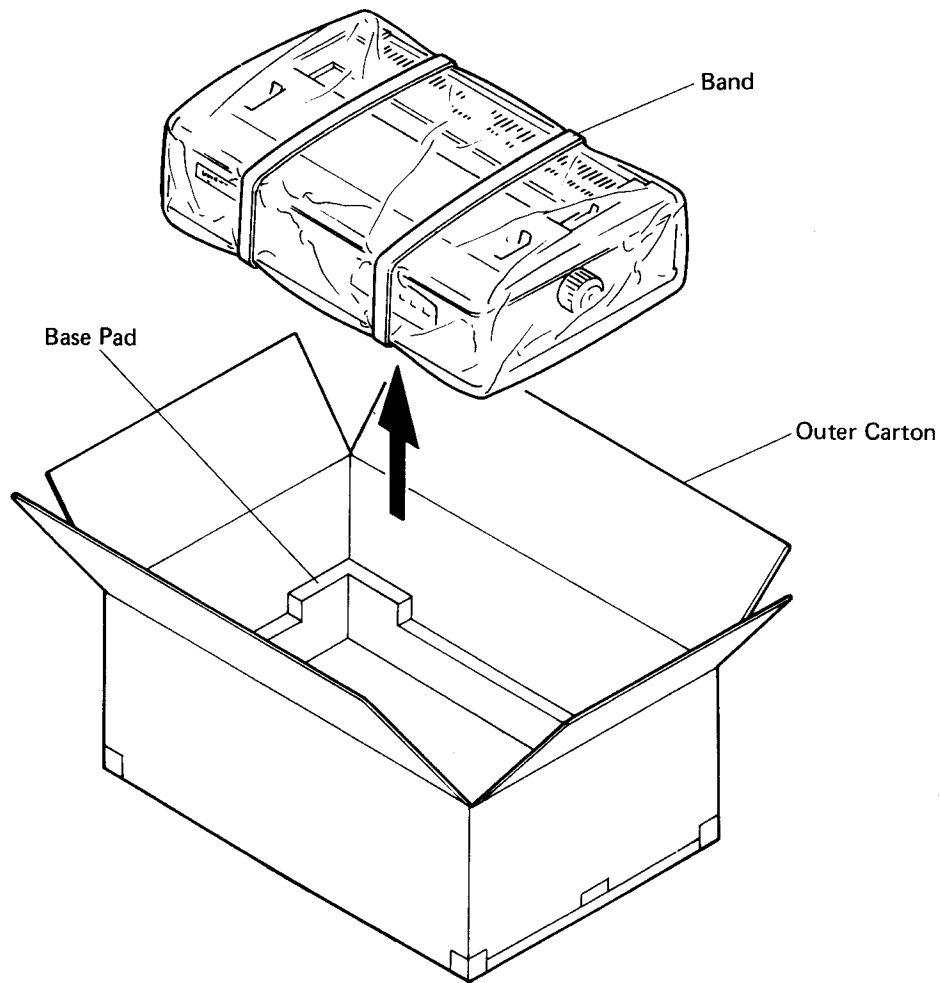

Figure C

(5) Remove the bands and the packing bag.

(6) Remove the front cover and the carriage stopper. See Fig. D.

(7) Install the print wheel (see section 2-8.) and the ribbon cartridge (see section 2-7.).

2-2. Installation

The MODEL 6400 is designed to rest comfortably on top of an ordinary table. However, this printer weighs approximately 14 kg, and when the carriage is moving from left to right at certain cycles, excessive vibration may occur. This factor should be taken into consideration when choosing an operating location. Overall, the MODEL 6400 is best suited to a sturdy, flat surface.

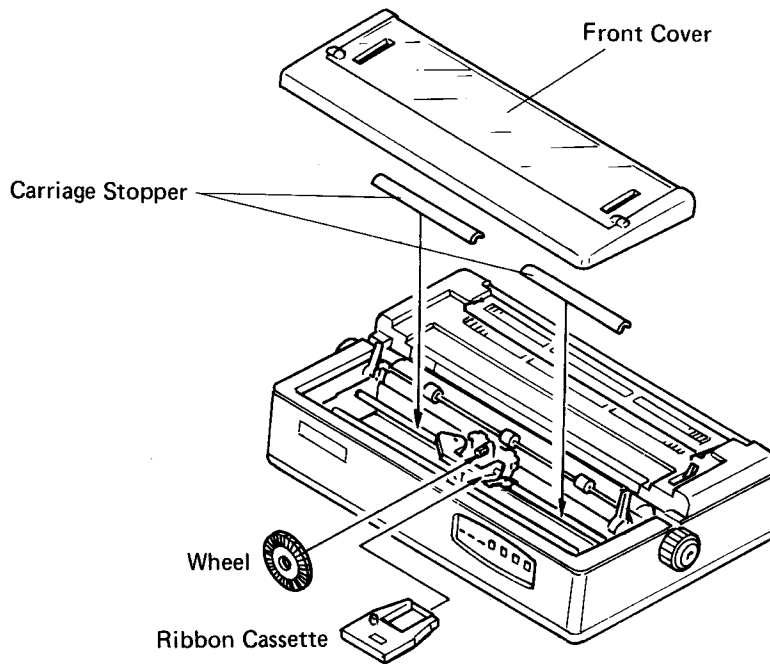

Figure D

2-3. Pre-Operation Checks

The following items should be checked before operating the printer:

(1) Power OFF

Before plugging-in the power cord, make sure the power switch at the lower left side of the printer is in the OFF position. The printer is ON when the marked side of the switch is depressed. See Fig. 1.



Figure 1

(2) Voltage Check

Before plugging-in the power cord, verify the rated voltage of the machine. The voltage rating appears on the nameplate at the back of the printer. The 90-127 V series is used in the United States; the 180-254 V series is used in Europe.

2-4. Control Panel

The control panel is located on the right front side of the printer. See Fig. 2.

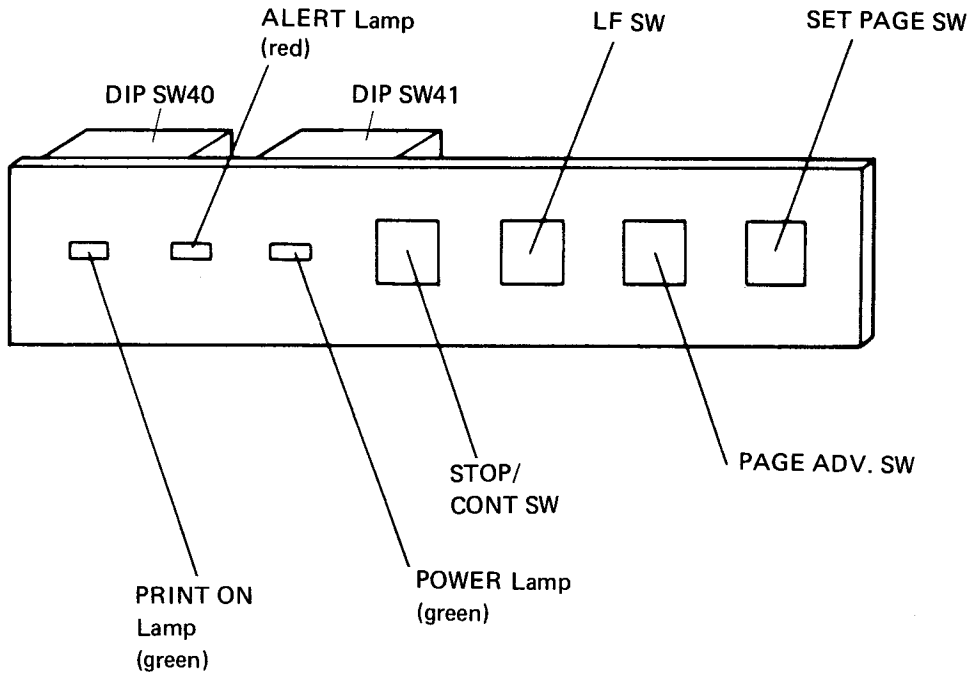

Figure 2

2-5. Paper Insertion

(1) Setting the Paper Out Mechanism.

The Paper Out mechanism can be attached to the rear-top of the printer by inserting the ends of the mechanism into the designated insertion slots (see Fig. 3).

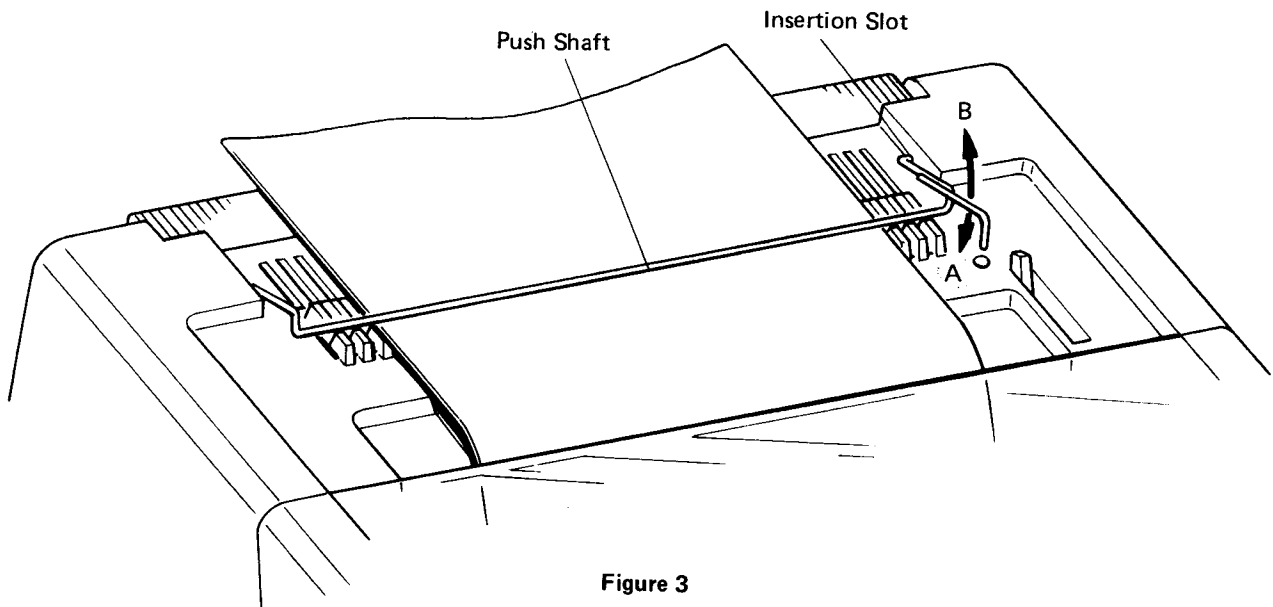

Figure 3

When using a single sheet of paper, the Paper Empty mechanism should be rendered inoperative, or the printer will remain in a perpetual state of "Paper Out" and will not function. To render the mechanism inoperative, simply move the push shaft in the direction of arrow "B." When using continuous paper, move the push shaft in the direction of arrow "A," and the mechanism will function as intended.

(2) Insertion

To insert paper into the printer, first set the Paper Release Lever to the CLOSED position and pull the Roller Pressure-Bar Lever forward, releasing the bar from the platen. Insert the paper along the edge of the paper guide, turning the platen knob. Once the paper emerges, the Roller Pressure-Bar Lever should be returned to its original position. The position of the paper can be fine-tuned by moving the Paper Release Lever to the OPEN position and adjusting the paper.

2-6. Print Alignment

Once the paper has been inserted into the printer, the print alignment can be adjusted using the Boat Line Aligner. See Fig. 4.

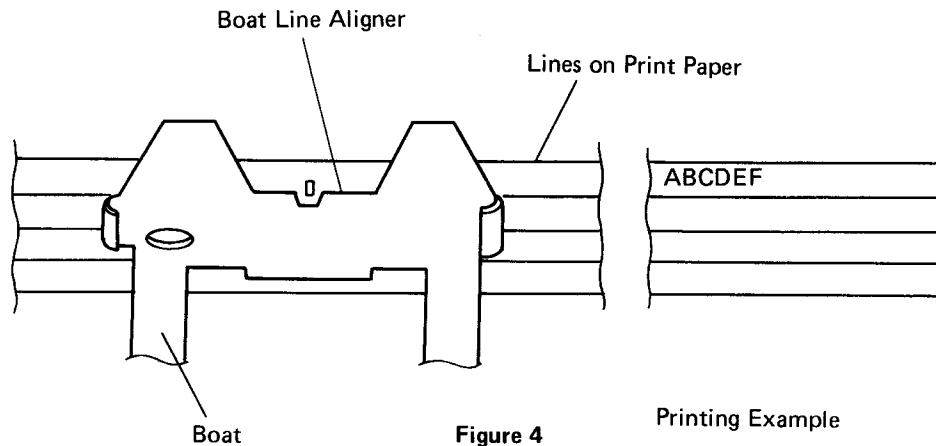

If the print paper line is aligned against the Boat Line Aligner as indicated above, the printed characters will appear as shown.

2-7. Ribbon Cartridge Replacement

When the printing impression is becoming faint, the ribbon cartridge should be replaced. After pushing down the top cover backward, remove the front cover with lifting up the both sides.

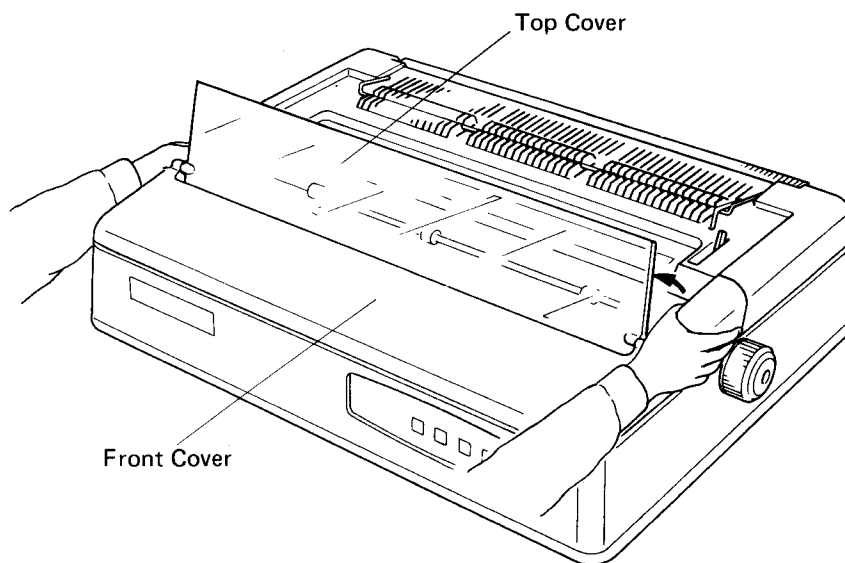

Figure 5

(1) Cartridge Removal

Remove the cartridge by lifting it up while pressing down on the carrier stop claws. See Fig. 6.

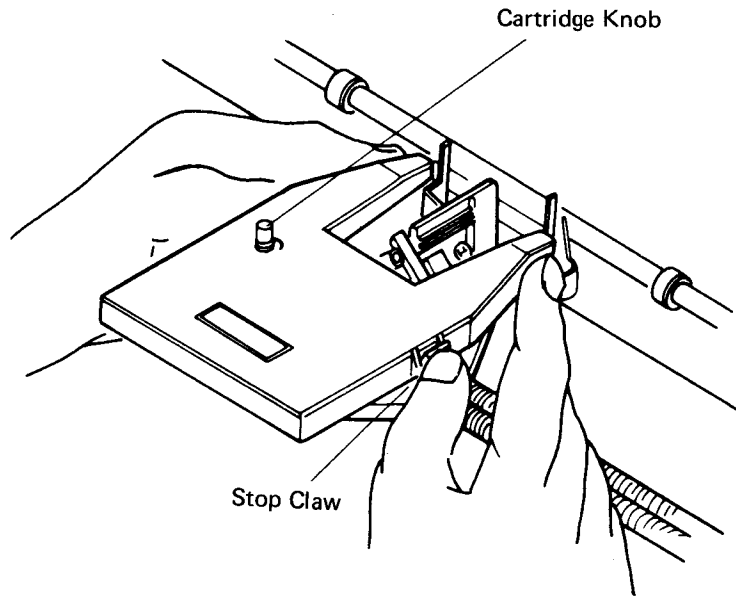

Figure 6

(2) Cartridge Installation

First, take up the slack in the ribbon by turning the knob in the direction of the arrow. Next, insert the cartridge from above, slipping the ribbon in-between the two guide plates at the left and right side of the boat. Now pull the cartridge down into place, fitting the stop claws into the appropriate cartridge slots. Turn the cartridge now again in the direction of the arrow, until a "click" is heard.

2-8. Print Wheel Replacement

If the spokes of the print wheel become bent, broken or otherwise inadequate, replace the print wheel. First, remove the front cover and the ribbon cartridge. Next, while firmly pushing down on the top surface of the hammer mechanism, push the lock lever down, releasing the hammer mechanism. See Fig. 7 and 8.

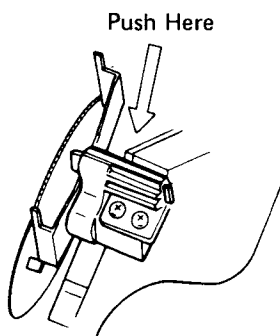

Figure 7

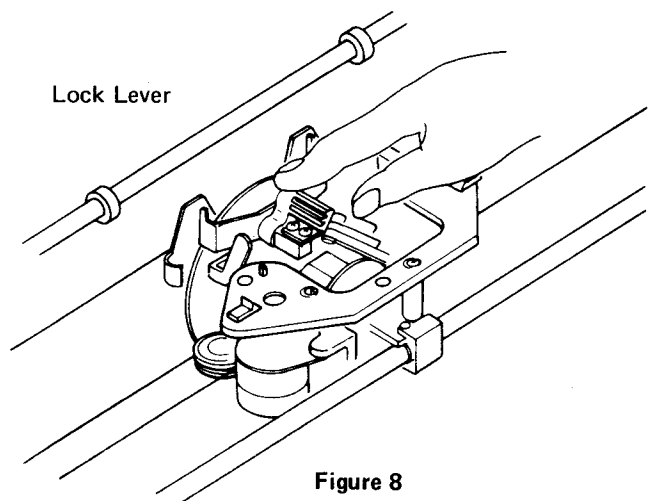

Figure 8

Once the hammer mechanism is released (and thus moveable), grasp the asterisk portion on both sides and tilt the mechanism toward the control panel, in the direction of the arrow. See Fig. 9.

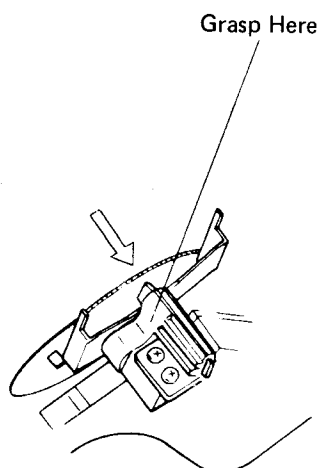

Figure 9

Now the hammer mechanism is in a position whereby the print wheel can be extracted. Grasp the print wheel by the circular rubber center and carefully pull upwards. See Fig. 10.

Print wheel installation is accomplished by following the removal steps in reverse order. Be sure to push the print wheel all the way down, noting that the gauge key protruding from the small hole in the print wheel should be fully emerged. Be sure that the lock lever locks into place when pulled upwards to secure the hammer mechanism.

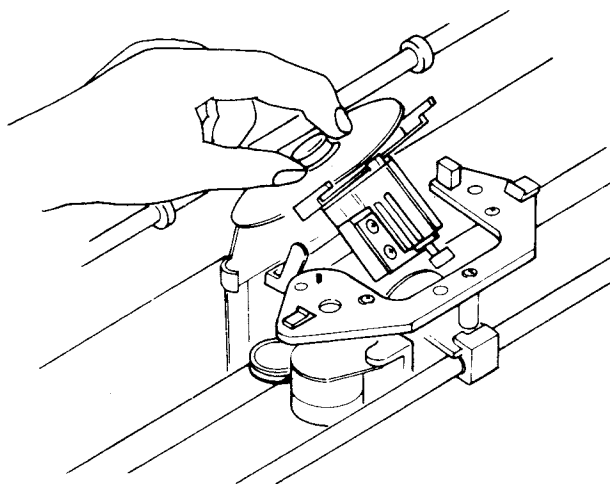

Figure 10

2-9. Automatic Self-Test

Automatic Self-Test enables a quick and simple check of print operation. To activate Self-Test, perform the following steps:

- (1) Turn power On. Make sure that the carriage has returned to the left home position. Turn power OFF.
- (2) Set the paper.
- (3) With the LF push button depressed, turn power ON. The printer will automatically print the pre-programmed test pattern, perform line feed, and print again.
- (4) MODEL 6400 Test Pattern: Self-Test for this model prints out all 96 characters, 10 blank spaces, and then 30 characters of alternative "H" and "I."
- (5) The LF, ON-LINE/OFF-LINE, PAGE ADV and SET PAGE switches do not function during Self-Test operation.
- (6) To stop Self-Test, turn power OFF.

2-10. Periodic Maintenance

The following periodic maintenance procedures are divided into monthly inspections, 6-month inspections (or every 1000 operation-hours) and yearly inspections (or every 2000 operation-hours).

PRECAUTIONS

Note 1: Turn power OFF before inspection.

Note 2: Use only the specified oils. Do not apply excessive oil, and do not apply oil to unspecified locations.

Note 3: Following inspection, make sure that no foreign matter is left in the printer. Replace the cover and confirm operation.

(1) Monthly Inspection

a) General Cleaning of the Carrier Block

Clean dirty areas with a soft cloth containing a small amount of methyl alcohol. Use a pair of tweezers to remove large paper particles.

Note 1: The ribbon cartridge and the print wheel are the only parts that should be removed during cleaning.

Note 2: Pay special attention to the paper guide, ribbon guide, flying hammer and hammer magnet shown in Fig. 11.

Note 3: Do not apply excessive methyl alcohol. Be sure that the alcohol is dry before confirming print operation.

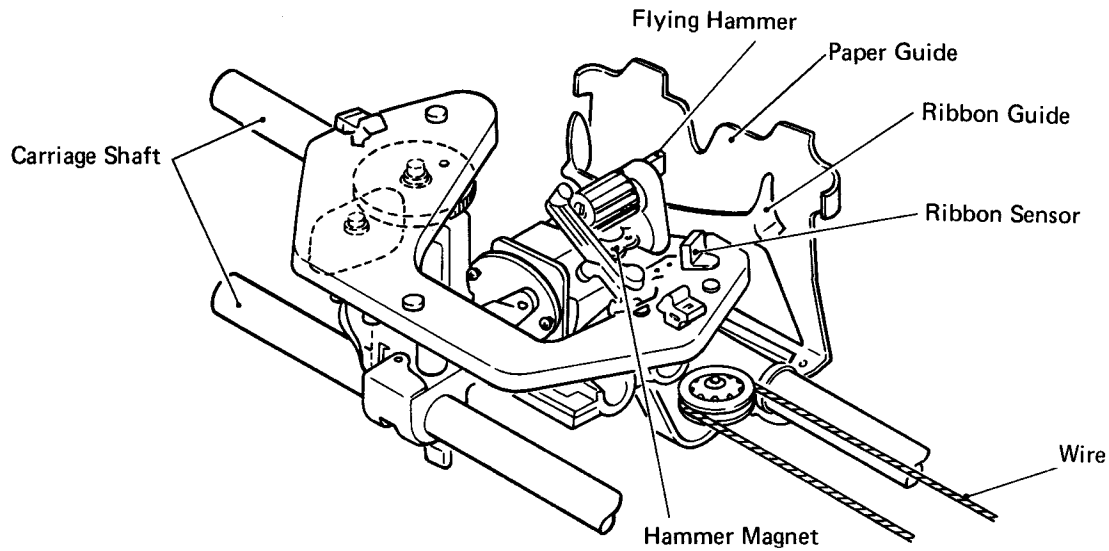

Figure 11

b) Carrier Shaft

Wipe off any dirt with a soft cloth containing a small amount of spindle oil.

c) Ribbon Sensor

When soiled, clean the luminous surface and light-receiving surface of the sensor with a soft, dry cloth.

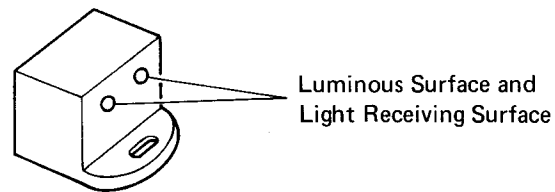

Figure 12

d) Print Wheel

Check the type surfaces for paper waste or dust. Replace the print wheel if any spokes are bent or broken (see section 2-8.).

(2) 6-Month Inspection (or every 1000 operation-hours)

a) Platen

Remove the platen. Thoroughly clean the rubber surface with a soft cloth containing a small amount of methyl alcohol. Check the rubber surface for unevenness or cracks. If found, replace the platen.

b) Paper Clamp Roller and Paper Feed Roller

If the print form is soiled by the paper clamp roller or the paper feed roller, remove the platen and remove any dirt with a soft cloth containing a small amount of methyl alcohol.

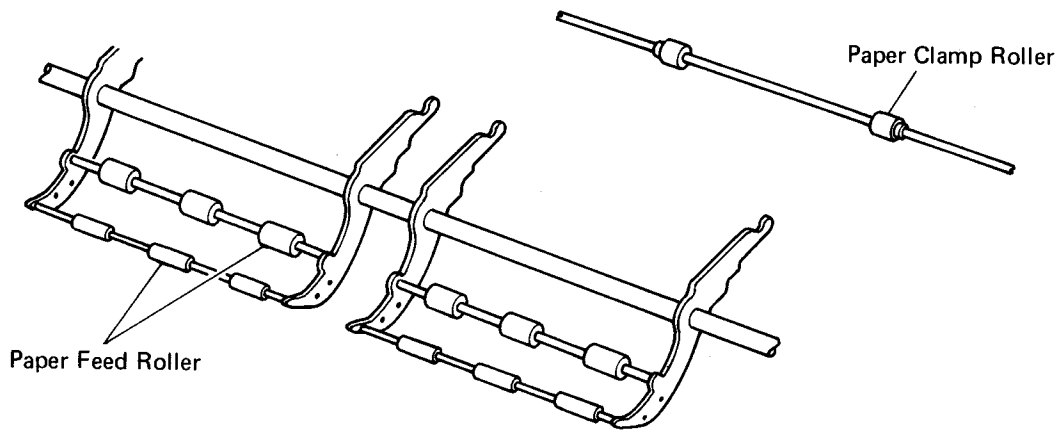

Figure 13

c) Home Position Detector

Carefully clean the detector by inserting a soft, dry cloth between the luminous surface and the light-receiving surface.

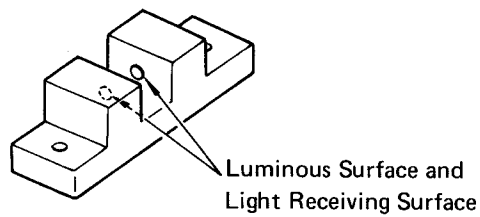

Figure 14

d) Carrier Wire

Check the carrier wire for excessive dirt or foreign matter. To clean, use a soft cloth containing a small amount of spindle oil. The carriage will slide easily along the wire. Replace the wire if damaged.

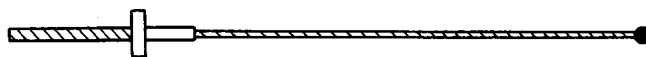

Figure 15

e) Covers

Clean the covers with a soft cloth containing a small amount of methyl alcohol.

(3) Yearly Inspection (or every 2000 operation-hours)

a) Platen Bearing

Remove the platen. Apply 2 or 3 drops of Morab Alloy #MW0-20 between the platen shaft and the bearing. Turn the bearing a few times and wipe off the oil on the surface.

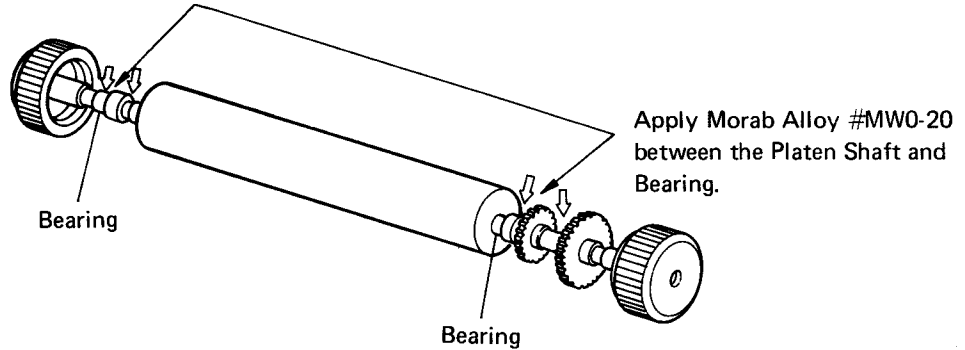

Figure 16

b) Hammer

Remove the hammer arm cap. If needed, apply a small amount of Mobilax No. 2 (grease) and replace the hammer arm cap. Do not apply excessive grease.

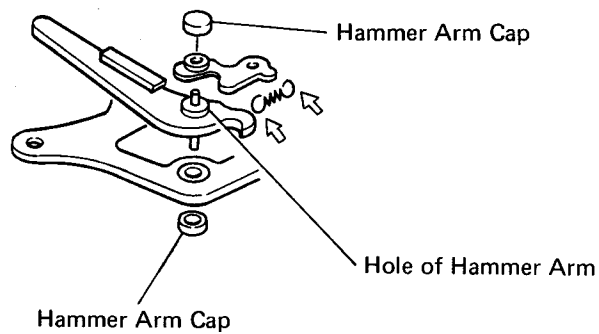

Figure 17

c) Other Lubrication Points

Check the following lubrication points. If lubrication is needed, use the specified oil.

1) Ribbon Deck Bearing and Carriage Bearing

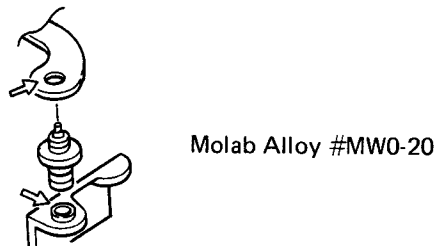

Figure 18

2) Paper Feed Roller

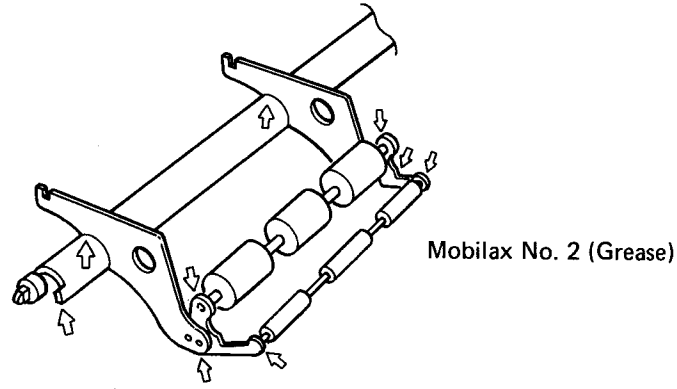

Figure 19

3) Paper Clamp Spring Hook

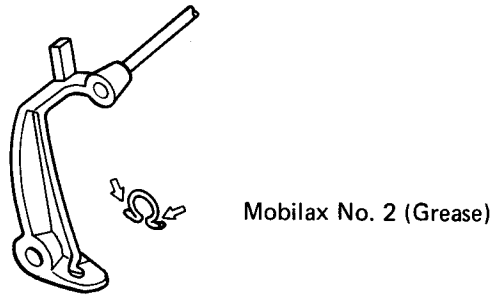

Figure 20

4) Print Wheel Motor Hook

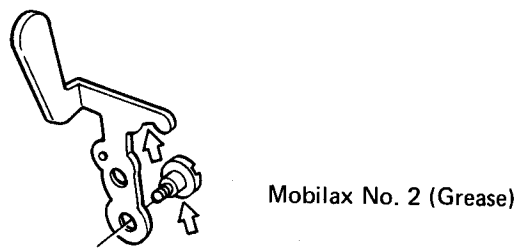
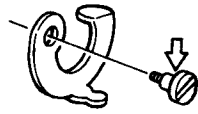

Figure 21

5) Platen Holder



Mobilax No. 2 (Grease)

Figure 22

6) Platen Gear

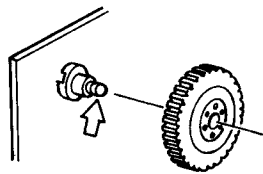

Figure 23

3. OPERATING/ALERT SWITCHES AND INDICATOR LAMPS

3-1. Operating Switches

(1) Power Switch

- a) This is a rocker-type switch located on the back-left side of the printer.
- b) This switch is used to turn the printer power ON/OFF.
- c) Power is turned on when the marked side is depressed.

(2) STOP/CONTINUE Switch

- a) This is a push switch located on the control panel.
- b) PRINT ON/PRINT OFF states alternate with every push.
- c) When placed PRINT OFF, print operation ceases immediately and a BUSY signal is sent to the host. However, the printer will continue to accept data from the host until the DATA BUFFER becomes full, after which all data received will be lost. Data stored in the buffer will be printed after the printer is placed PRINT ON.
- d) Data stored in the buffer during an PRINT OFF state is erased if the power supply is turned off.
- e) In line mode, data stored in the buffer during an PRINT OFF state will be printed (once the printer is PRINT ON) only after a print command code is received.

(3) LF (Line Feed) Switch

- a) This is a push switch located on the control panel.
- b) One line feed occurs with every push. If the switch is depressed for more than half seconds, continuous line feed will occur until the switch is depressed again.
- c) Line feed operation is independent of the STOP/CONTINUE switch.
- d) A line feed pitch established by an ESC sequence takes priority over normal line feed operation.
- e) LF is ignored when the printer is executing a given command in serial mode or when the printer is printing a line in line mode.
- f) LF is ignored during Self-Test operation.

(4) PAGE ADV Switch

- a) This is a push switch located on the control panel.
- b) When this switch is depressed, the paper is fed to the next TOF (Top Of Form) position.
- c) Form Length is set up by DIP switch for FF and ESC FF n.
- d) PAGE ADV operation is independent of the STOP/CONTINUE switch.
- e) PAGE ADV is ignored when the printer is executing a given command in serial mode or when the printer is printing a line in line mode.
- f) PAGE ADV is ignored during Self-Test operation.

(5) SET PAGE Switch

- a) This is a push switch located on the control panel.
- b) When this switch is depressed, the line on which the carriage rests at that moment becomes the TOF (Top Of Form). When the operation of this switch is acknowledged by the printer, the carriage will move three spaces to the right and then return to its original position.
- c) TOF is also set at the current line position whenever power is applied or when the printer receives an ESC CR P command.
- d) SET PAGE is ignored when the printer is executing a given command in serial mode or when the printer is printing a line in line mode.
- e) SET PAGE operation is independent of the STOP/CONTINUE switch.

3-2. Alert Switches

(1) PAPER OUT Switch

- a) This is a microswitch attached to the paper sensor block.
- b) This switch is activated by a small rod attached to the Paper Out mechanism (See section 2-5.). As the last sheet of paper passes through the mechanism, the small rod falls through a hole in the top cover of the printer (see Fig. 3) and activates the switch.
- c) When the sensor detects that the paper end is near (19 mm from the end), the printer goes PRINT OFF, stops printing, and lights up the red ALERT lamp on the control panel. However, if Paper Out is detected during a feed motion, the printer stops after such feed motion is completed.
- d) To restore print operation, replenish the paper supply and place the printer PRINT ON.

(2) COVER OPEN Switch

- a) This is a microswitch attached to the main cover of the printer.
- b) This switch is activated when the front cover is open.
- c) When Cover Open is detected, the printer goes PRINT OFF, stops printing, and lights up the red ALERT lamp on the control panel.
- d) To restore print operation, securely close the front cover and place the printer PRINT ON.

(3) RIBBON OUT Sensor

- a) This is a reflecting photoelectric sensor attached to the carriage.
- b) This sensor is activated when the ribbon comes to an end.
- c) When Ribbon Out is detected, the printer goes PRINT OFF, stops printing, and lights up the red ALERT lamp on the control panel.
- d) To restore print operation, replace the ribbon and place the printer PRINT ON.

3-3. Indicator Lamps

The following lamps are located on the control panel.

(1) PRINT ON Lamp (green LED)

This lamp is lit when the printer is operating, except during Self-Test operation.

(2) PAPER OUT (ALERT) Lamp (red LED)

This lamp is lit when Paper Out, Ribbon Out, Cover Open and PW Motor errors occur.

(3) POWER Lamp (green LED)

This lamp is lit when printer power is on.

4. IEEE-488 INTERFACE SPECIFICATION

4-1. IEEE Connector Pin Diagram

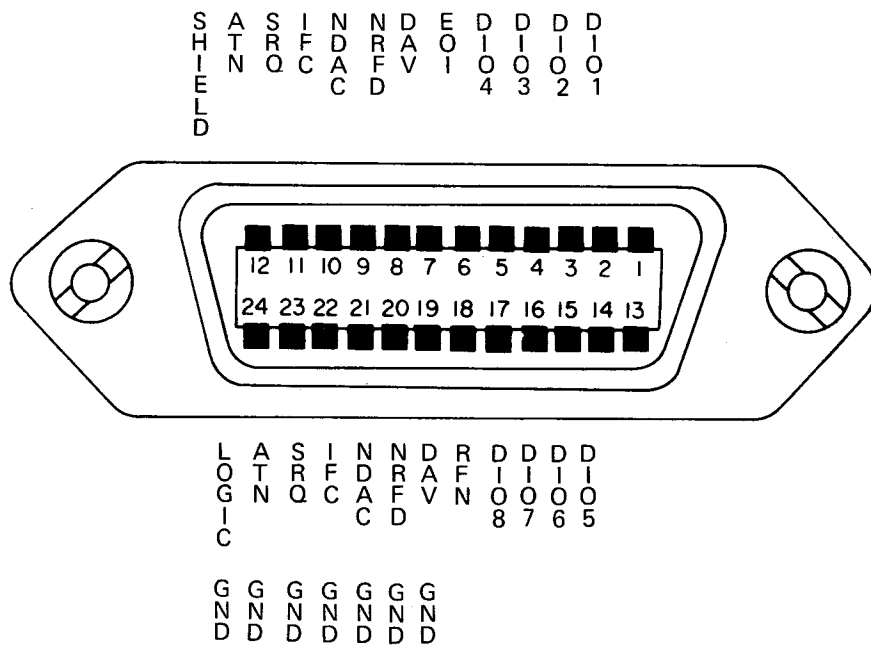

4-2. Signal Lines

(1) DIO 1-8

Eight data lines which are placed in the command mode when the ATN line is LOW, and in the data mode when HIGH.

(2) DAV (Data Valid)

Indicates that the signal which has been sent from the controller to the DIO line is valid.

(3) NRD (Not Ready For Data)

Goes LOW when the data on the DIO lines cannot be accepted (HIGH when it can be received).

(4) NDAC (Not Data Accepted)

This is the signal which indicates the completion of data acceptance. It is LOW when the acceptance has not been completed.

(5) ATN (Attention)

This is the signal to place the DIO line signals in the command mode or data mode. The command mode is assumed when the signal is LOW, and the data mode when HIGH.

4-3 Change of the Device Number

The device number can be changed by changing the connection of jumper line on the PC board for IEEE Interface. It is recommended that you let your local dealer make these jumper changes for you.

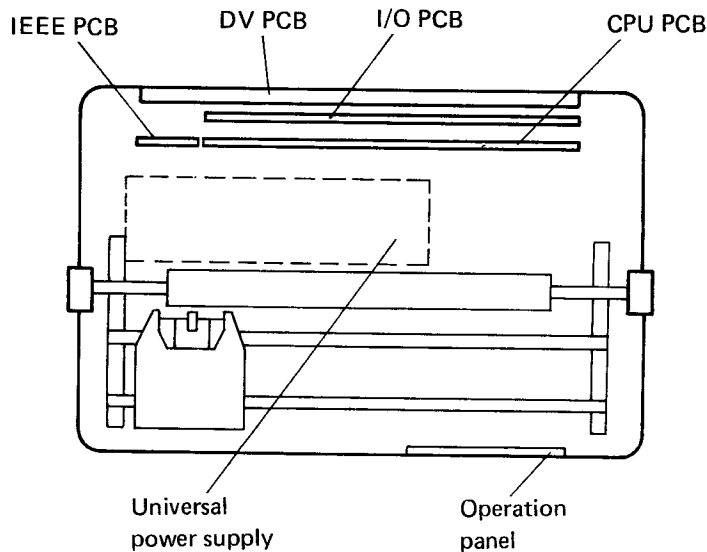

○ Connect
 X Non Connect

IEEE Board

- 8 ● J4 ●
- 4 ● J3 ●
- 2 ● J2 ●
- 1 ● J1 ●

Initial Shipment Setting

Device number	Jumper line			
	J1	J2	J3	J4
1	○	X	X	X
2	X	○	X	X
3	○	○	X	X
4	X	X	○	X
5	○	X	○	X
6	X	○	○	X
7	○	○	○	X
8	X	X	X	○
9	○	X	X	○
10	X	○	X	○
11	○	○	X	○
12	X	X	○	○
13	○	X	○	○
14	X	○	○	○
15	○	○	○	○

5. DIP SWITCH FUNCTIONS

5.1 DIP Switches

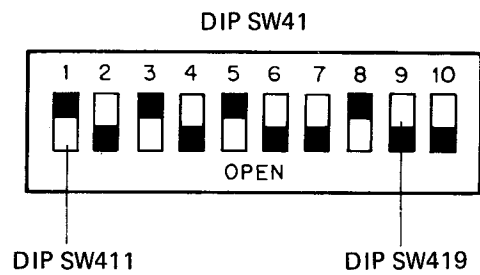
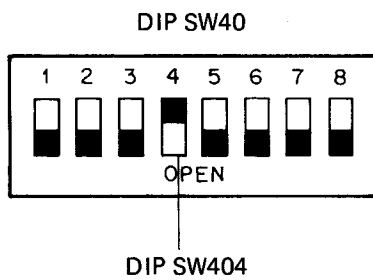

Condition SW No.	Open	Close	Remarks	Factory Setting
SW404	Auto Line Feed Disable	Auto Line Feed Enable		Close
SW411	Serial Mode	Line Mode	Mode Selection	Close
412	CBM Code	ASCII Code		Open
413	Auto Space Off	Auto Space On		Close
414	12/120	10/120	Pica, Elete	Open
415	PS On	PS Off		Close
416	Data 1 *1		From feed amount	Open
417	Data 2		is specified in	Open
418	Data 4		serial mode.	Close
419	Data 8			Open

*1. Open=1

Close=0

Data 1=1 inch

- Note 1: Changes to DIP switch positions are not valid until the printer is switched to OFF LINE and then back to ON LINE.
- 2: The DIP SW No. which is not listed upon the table above is not used.

Supplementary Explanation: Automatic Carriage Feed

1. The priority order of automatic carriage feed is determined by the following chart.

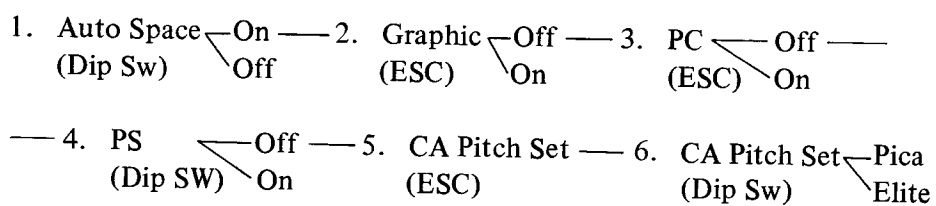

(1) Auto Line Feed

FUNCTION	SW404
DISABLE	OPEN
ENABLE	CLOSE

If this code is enabled, the printer will perform a LINE FEED with each CARRIAGE RETURN command received.

(2) Serial of Line Mode

In serial mode, the printer prints the data in series as received by the host. In line mode, the data remains in the buffer until one full line of data is received, or until a string of data is received followed by a print command; then the line of data is printed. Line mode printing is performed bidirectionally.

MODE	SW411
SERIAL	OPEN
LINE	CLOSED

(3) Code Chart Selection

CBM Code chart and ASCII Code are switch-selectable.

CODE CHART	SW 412
CBM	OPEN
ASCII	CLOSED

(4) Auto Carriage Space

In serial mode, automatic spacing of the carriage is switch-selectable

MODE	SW413
AUTO SPACE OFF	OPEN
AUTO SPACE ON	CLOSED

 (ST)

(5) Carriage Space Mode

Several carriage spacing pitches are switch-selectable. Proportional spacing (PS) varies the spacing between characters in accordance to character size. Pica pitch prints 10 characters per inch, with each character 12/120th of an inch in size. Elite pitch prints 12 characters per inch, with each character 10/120th of an inch in size.

Note: A spacing pitch provided for an ESC sequence takes priority over the pitch established by the carriage space mode switch.

PS	SW415
PS ON	OPEN
PS OFF	CLOSED

PITCH	SW414
ELITE	OPEN
PICA	CLOSED

(ST)

Note: For PS mode setup, use a Qume print wheel (P.N. 80961).

(6) Form Feed Length

A form feed length of 1 to 15 inches can be selected by the use of DIP Switches. Each switch represents a certain number of inches, as shown below.

No. of INCHES	SW NO.
1 INCH	SW416
2 INCHES	SW417
4 INCHES	SW418
8 INCHES	SW419

The "inch value" of a switch is obtained when the switch is OPEN. For example, to set the form feed length to 11 inches, set SW416, SW418 and SW419 to the OPEN position, and SW417 to CLOSED.

(7) IFC (Interface Clear)

When a LOW pulse is input into this line, the printer will be reset.

(8) Others

The SRQ, REN, and EOI are not used.

5.2 Examples of DIP Switch Setting

The following are some examples of DIP Switch Setting.

BASIC program

SW401: CLOSE (Auto LINEFEED enable)

SW412: OPEN (CBM Code)

Word Pro

SW404: CLOSE (Auto LINEFEED enable)

SW412: CLOSE (ASCII Code)

Note: Select the Printer type: Diablo

Word Craft80

SW404: OPEN (Auto LINEFEED disable)

SW412: CLOSE (ASCII Code)

Note: Select the Printer type: RICOH

Visi Calc

SW404: CLOSE (Auto LINEFEED enable)

SW412: OPEN (CBM Code)

Note: Select the Printer type: PET

Commodore Assembler

SW404: OPEN (Auto LINEFEED disable)

SW412: OPEN (CBM Code)

Note: Select the Printer type: IEEE PRINTER

6. STANDARD CONTROL COMMANDS

NO.	CODE NAME	SERIAL PRINT MODE	LINE PRINT MODE
1	BS Back (08H) Space	<ol style="list-style-type: none"> 1) The carriage returns one character space. 2) The carriage returns ignoring the left margin. 3) The carriage does no move by a single space when the printer continuously recieves this code, but it moves as a high speed tab. 4) The carriage moves even in the absence of the character code when the printer does not receive the data within about 50 ms after receiving this code. 5) Spacing is performed regardless of AUTOSPACE switch. The spacing amount depends on that specified by the spacing switch or ESC. 	<ol style="list-style-type: none"> 1) The carriage returns one character space. 2) This code does not act as a print command. 3) If this code is received continuously the number of spaces is counted and the carriage moves as a high speed tab.
2	HT Hori- (09H)zontal Tab	<ol style="list-style-type: none"> 1) The carriage moves to the nearest right horizontal tab position that has been specified beforehand. If no tab position was set in the right direction, the carriage moves to right margin. 	<ol style="list-style-type: none"> 1) The carriage moves to the nearest right horizontal tab position that has been specified beforehand. 2) Since this code does not act as a command, a print command code is needed at the end of a line.
3	LF Line (0AH)Feed	<ol style="list-style-type: none"> 1) The printer feeds one line. 2) The LF amount is 1/6 inch. The line is fed by the amount specified by the ESC code. When BOTTOM MARGIN is set and the printer performs the line feed while on the BOTTOM MARGIN line, the printer automatically feeds to TOP MARGIN. 	Same as the serial print mode.
4	FF Form (0CH) Feed	<ol style="list-style-type: none"> 1) The printer feeds to the next TOF (or TOP MARGIN) position. 2) The Form Length is set by the panel PCB DIP switch and ESC code. 	Same as the serial print mode.
5	CR Carriage (0CH) Return	<ol style="list-style-type: none"> 1) The printer moves the carriage to the left margin and one line feed. 	<ol style="list-style-type: none"> 1) The carriage stops at the last printing position after printing and one line feed. 2) Act as a print command code.
6	SI Shift IN (0FH)	<ol style="list-style-type: none"> 1) The printer is released from the programmed mode and returns to the normal mode. 	Same as the serial print mode.

NO.	CODE NAME	SERIAL PRINT MODE	LINE PRINT MODE
7	ESC Escape (1BH)	1) For details refer to other pages.	Same as the serial print mode.
8	CS Carriage (8DH) Stand	1) The printer moves the carriage to the left margin.	1) The carriage stops at the last printing position after printing. 2) Act as a print command code.
9	SP Space (20H)	1) The carriage spaces one character. 2) The carriage moves ignoring the left or right margin. 3) The carriage does not move by a single space when the printer continuously receives this code, but it moves as a high speed tab. 4) The carriage moves even in the absence of the character code when the printer does not receive the data within about 50 ms after receiving this code. 5) Spacing is performed regardless of AUTOSPACE switch. The spacing amount depends on that specified by the spacing switch or ESC sequence.	1) The carriage spaces one character. 2) If this code follows one after another, the printer counts the number of spaces and moves the carriage as a high speed tab.

NOTE: Selection of BS Mode Functions by JY Jumper (In Serial Mode)
 JY Jumper Closed – Print, move, print, move etc.
 JY Jumper Open --- Move, print, move, print etc.
 The JY jumper is open when the printer is delivered.

7. ESC EXPANSION COMMAND

7-1 Description of Command

- (a) ESC 1 Set Horizontal Tab Stop
This code set the horizontal tab in the location where the carriage is presently positioned.
Up to 16 positions can be set.
- (b) ESC 2 Clear All Horizontal Tab
This code clears all the horizontal tabs.
- (c) ESC 8 Clear Individual Horizontal Tab Stop
This code clears the horizontal tab in the location where the carriage is presently positioned.
- (d) ESC 9 Set Left Margin
This code sets a left margin in the location where the carriage is presently positioned.
- (e) ESC T Set Top Page Margin.
This code sets a Top page margin in the location where paper is presently positioned.
- (f) ESC L Set Bottom Page Margin
This code sets a Bottom Page Margin in the location where paper is presently positioned.
- (g) ESC C Clear Top and Bottom Page Margin
This code clears the Top and Bottom Page Margin.
- (h) ESC 5 Forward Print Mode ON
This code clears the Backward print mode.
This code is effective in serial mode only.
- (i) ESC 6 Backward Print Mode Set
During Backward printing, each character printed causes incremental carriage movement to the left, just opposite of carriage motion during forward printing.
Note, however, that tabbing operations, carriage return, and all paper movement functions are not affected by this print mode.
This mode is cancelled by ESC 5 or CR code.
This code is effective in serial mode only.
- (j) ESC LF Negative Line Feed
This code acts as a negative line feed, causing the paper to moved down one line (backward.)
- (k) ESC D Negative Half Line Feed
This code moves paper down by a half line (1/2 of the VM1). if the VMI is set by some odd number in terms of multiples of 1/48 inch, the amount of the movement is determined on the round-off basis.
- (l) ESC U Hafl Line Feed
This code moves a paper up by a half line.
If VMI is set by some odd number in terms of multiples of 1/48 inch, the amount of the movement is determined on the round-off basis.

- (m) ESC US n Set Horizontal Motion Index
 The standard HMI can be altered by executing this code.
 When spacing, the carriage will move after printing a character by the number of designated Decimal Data times 1/120 inch increments.

$$\text{HMI} = (\text{Decimal Data} - 1) \times 1/120 \text{ inches}$$
 (The Maximum Data is 127.)
 (ex.) When Decimal Data is 20, HMI will be 20/120", which is, 1/6".
- (n) ESC RS n Set Vertical Motion Index
 The standard VMI can be altered by executing this code.
 The paper feed amount, VMI, for each line feed, negative line feed, etc. is equal to the number of designated Decimal Data times 1/48 increments.

$$\text{VMI} = (\text{Decimal Data} - 1) \times 1/48 \text{ inches}$$
 (The Maximum Data is 127.)
- (o) ESC FF n Set Line Per Page
 The number of lines per page can be altered by using this code with the Decimal Data. Here, the Decimal Data is equal to the desired number of lines per page. The minimum number of lines per page is 1.
 The maximum number is 126.

$$\text{Form Length} = \text{Decimal Data} \times \text{VMI inches.}$$
- (p) ESC S When this code is executed, TOF is set at the current position of the paper. This code clears the Top and Bottom page margins.
- (q) ESC HT n Absolute Horizontal Tab
 By this command the carriage can be positioned directly at any of the first 126 print positions without having set any tab stops. The command sequence for this is a Decimal Data represented by ESC HT n, where the value of the Decimal Data indicates the desired print position.
 The leftmost print position is considered to be 1.

$$\text{Horizontal Position} = (\text{Decimal Data} - 1) \times \text{HMI}$$
 If the horizontal position is beyond the right margin, this code is ignored.
- (r) ESC VT n Absolute Vertical Tab
 By this command the paper can be moved to any of the 126 possible lines on the page.
 Absolute Vertical Tab is initiated by executing a Decimal Data represented by the sequence ESC VT n, where the value of the Decimal Data selected determines the line to be reached.
 The top print line of the page is assigned the value 1.

$$\text{Vertical Position} = (\text{Decimal Data} - 1) \times \text{VMI}$$
 If vertical position is beyond the Bottom Margin and before the Top Margin, this code is ignored.

- (s) ESC Y Printing a character “£”
 This code instructs printer to print a character “£” at position 14 of the print wheel.
- (t) ESC Z Printing a character ‘⌋’
 This code instructs the printer to print a character ‘⌋’ at position 13 of the print wheel.
- (u) ESC CR P Remote Reset
 When the printer receives this code, it goes to the same state as that power source is applied, that is:
- The carriage and the print wheel are restored.
 - Internal circuits are initialized.
 - The data buffer is cleared.
 - The printer is in “PRINT ON” state.
- (v) ESC / Enable Auto Backward Printing.
 Enable Line Mode.
- (w) ESC \ Disable Auto Backward Printing
 Enable Serial Mode.

7-2 Word Processing Functions

- (a) ESC P Proportional Space ON
 This code is used to set a proportional space mode.
 This code is cancelled by ESC Q, ESC S, ESC X code.
 These PS unit values represent one-half the width required by each proportionally spaced character.
 The letter “A”, for example has a PS value of 6, which is one-half of the 12/120” spacing a “A” requires. Carriage movement is calculated by adding the PS unit value of the character just printed to the PS unit value of the character to be printed.
 Thus, if the character “i” is to follow a “A” the carriage just move 8/120” before printing the “i”.
 This is the sum of the PS unit values of the “i” (2) and “A” (6).
- (b) ESC Q Proportional Space OFF
 This code is used to cancel the proportional space mode and sets in back to the spacing mode specified before ESC P was received.
- (c) ESC DC1 n Offset Selection
 For proportional space printing, to add or subtract a constant to each value of the table, the sequence ESC DC1 (byte) should be used.
 The value of the “byte” is added to each value of the table, or HMI if it is controlling size, as well as to the space character.
 This continues until another ESC DC1 (byte) sequence is received, or until offset is cleared by a carriage return or the sequence ESC X.
- Bits 0 - 5 = Size of offset
 Bit6 = Sign of offset (1 = negative)
- If the resulting character size is zero or less, no carriage movement will occur.

- (d) ESC E Auto Underscore ON
The printed characters are automatically underlined upon receipt of this code.
This mode is cancelled by ESC R and ESC X code.
- (e) ESC R Auto Underscore OFF
This code is used to cancel the automatic underscore mode.
- (f) ESC O Bold Print Mode ON
This code is used to double print over the same character.
The normal ribbon advance occurs between character strikes.
This mode is cancelled by CR and ESC & and ESC X code.
- (g) ESC W Shadow Print Mode ON
This code is used to let the printer to shadow.
Shadow print is a printing method to shadow a character by printing one character two times with carriage movement of 1/120 inch.
This mode is cancelled by CR and ESC & and ESC X code.
- (h) ESC & Bold/Shadow Print Mode OFF
This code is used to cancel the Bold Over Print or the Shadow Print mode.
Note: The automatic Underscore, Bold Over Print and Shadow Print modes supersede the other.
If the Automatic Underscore mode is set, the other two modes become ineffective.
- (i) ESC % Carriage Settling Time Control
The carriage settling time can be increased to 20 msec by issuing the sequence ESC %.
This provides more time for mechanical vibrations to damp out before printing to improve print quality, with least sacrifice of print speed.
The sequence ESC N will restore the normal carriage settling time.
- (j) ESC N Carriage Settling Time Control Clear.
This code is used to cancel the Carriage settling time control mode.
- (k) ESC SOM Program Mode ON
The printer enters a program mode upon receipt of this code.
In the program mode, character parameters are given by a two-byte word, consisting of character code, hammer impact code and carriage spacing pitch code.
Upper byte is character code by CBM. Lower byte is used for control code.
This mode is cancelled by SI and ESC X code.

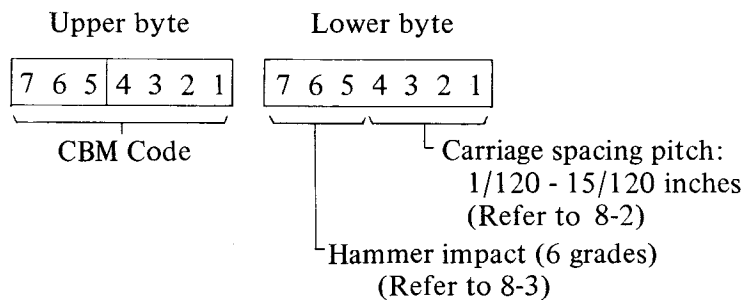

(l) ESC X

Cancel All WP Modes

This code cancels the WP Modes of the followings:

Auto Underscore

Bold Overprint

Shadow Print

Program Mode

Offset Selection

Proportional Space

(m)ESC

Backspace 1/120

BS

This code moves the carriage by a 1/120 inch left.

8. TABLES

8-1 PS Carriage Movement Data

UPPER BYTE

		UPPER BYTE					
		2	3	4	5	6	7
LOWER BYTE	0	(£) 4 (b) 4	0 4	@ 6	P 4	(') 0 (2) 4	p 4
	1	! 3	1 4	A 6	Q 6	a 4	q 4
	2	" 4	2 4	B 5	R 6	b 4	r 4
	3	+ 4	3 4	C 5	S 4	c 4	s 3
	4	\$ 4	4 4	D 6	T 5	d 4	t 3
	5	% 6	5 4	E 5	U 6	e 4	u 4
	6	& 6	6 4	F 5	V 6	f 3	v 4
	7	' 2	7 4	G 6	W 7	g 4	w 6
	8	(3	8 4	H 6	X 6	h 4	x 4
	9) 3	9 4	I 3	Y 6	i 2	y 4
	A	* 4	: 3	J 3	Z 5	j 2	z 4
	B	+ 4	; 2	K 6	[4	k 4	({) s 4
	C	' 2	< 4	L 5	(\) [®] 6	ˆ 2	(1) 91 (2) 6
	D	- 4	= 4	M 6] 4	m 7	(}) + 4
	E	. 2	> 4	N 6	(^) [©] 6	n 4	(~) TM 6
	F	/ 3	? 4	O 6	- 5	o 4	(_) = 5



Print wheel: Qume (P.N. 80961)

8-2 Program Mode Hammer energy data

UPPER BYTE

	2	3	4	5	6	7
0	£ 6	0 6	@ 5	P 5	. 1	p 5
1	! 2	1 3	A 5	Q 6	a 4	q 6
2	" 2	2 4	B 6	R 6	b 5	r 3
3	+ 6	3 4	C 4	S 5	c 3	s 4
4	\$ 4	4 5	D 5	T 4	d 5	t 4
5	% 5	5 4	E 4	U 4	e 4	u 4
6	& 4	6 5	F 4	V 4	f 4	v 3
7	' 1	7 3	G 5	W 6	g 5	w 5
8	(2	8 6	H 6	X 5	h 4	x 4
9) 2	9 5	I 4	Y 4	i 2	y 4
A	* 3	: 2	J 4	Z 4	j 3	z 4
B	+ 3	; 2	K 5	[3	k 4	{ 2
C	' 1	< 2	L 4	\ 3	l 3	l 2
D	- 2	= 3	M 6] 3	m 5	} 2
E	. 1	> 2	N 6	^ 1	n 4	~ 1
F	/ 3	? 3	O 5	- 2	o 4	~ 2

LOWER BYTE

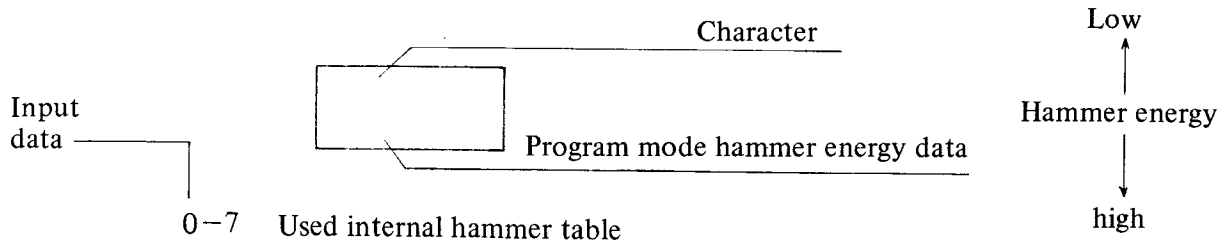

Print wheel: Diablo #38100-01

8-3 Character Code Table

8-3-1 CBM Code Table

b ₇	b ₆	b ₅	b ₄	b ₃	b ₂	b ₁	b ₀		0	1	2	3	4	5	6	7	8	9	A	B	C	D	E	F										
0	0	0	0	0	0	0	0	0	0	0	0	0	0	0	0	0	1	1	1	1	1	1	1	1										
0	0	0	0	0	1	1	1	1	0	0	0	0	1	1	1	0	0	0	0	1	1	1	1											
0	0	1	1	0	0	1	1	0	0	0	1	1	0	0	1	1	0	0	1	1	0	0	1	1										
0	1	0	1	0	1	0	1	0	0	1	0	1	0	1	0	1	0	1	0	1	0	1	0	1										
0	0	0	0	0	0	0	0		SP	0	@	p	SP	SP					SP	SP	,	P	SP	SP										
0	0	0	1	1					(DC1)	!	1	a	q	SP	SP					SP	SP	A	Q	SP	SP									
0	0	1	0	2					"	2	b	r	SP	SP							SP	SP	B	R	SP	SP								
0	0	1	1	3					#	3	c	s	SP	SP									SP	SP	C	S	SP	SP						
0	1	0	0	4					\$	4	d	t	SP	SP											SP	SP	D	T	SP	SP				
0	1	0	1	5					%	5	e	u	SP	SP													SP	SP	E	U	SP	SP		
0	1	1	0	6					&	6	f	v	SP	SP														SP	SP	F	V	SP	SP	
0	1	1	1	7					'	7	g	w	SP	SP															SP	SP	G	W	SP	SP
1	0	0	0	8	BS				(8	h	x	SP	SP															SP	SP	H	X	SP	SP
1	0	0	1	9	HT)	9	i	y	SP	SP															SP	SP	I	Y	SP	SP
1	0	1	0	A	LF				*	:	j	z	SP	SP															SP	SP	J	Z	SP	SP
1	0	1	1	B	(VT)ESC				+	;	k	[SP	SP															SP	SP	K	{	SP	SP
1	1	0	0	C	FF				,	<	l	£	SP	SP															SP	SP	L		SP	SP
1	1	0	1	D	CR				-	=	m]	SP	SP	CS														SP	SP	M	}	SP	SP
1	1	1	0	E	(SO)(RS)				.	>	n	^	SP	SP															SP	SP	N	~	SP	SP
1	1	1	1	F	SI (US)				/	?	o	-	SP	SP															SP	SP	O	⌋	SP	\

8-3-2 ASCII Code Table

b ₇	b ₆	b ₅	b ₄	b ₃	b ₂	b ₁	b ₀		x	x	x	x	x	x	x	x
0	0	0	0	0	0	0	0		0	0	0	0	1	1	1	1
0	0	1	1	0	0	1	1		0	0	1	1	0	0	1	1
0	1	0	1	0	1	0	1		0	1	0	1	0	1	0	1
0	0	0	0	0	0	0	0		SP	0	@	p	,	p		
0	0	0	1	1					(DC1)	!	1	A	Q	a	q	
0	0	1	0	2					"	2	B	R	b	r		
0	0	1	1	3					#	3	C	S	c	s		
0	1	0	0	4					\$	4	D	T	d	t		
0	1	0	1	5					%	5	E	U	e	u		
0	1	1	0	6					&	6	F	V	f	v		
0	1	1	1	7					'	7	G	W	g	w		
1	0	0	0	8	BS				(8	H	X	h	x		
1	0	0	1	9	HT)	9	I	Y	i	y		
1	0	1	0	A	LF				*	:	J	Z	j	z		
1	0	1	1	B	(VT)ESC				+	;	K	[k	{		
1	1	0	0	C	FF				,	<	L	\	l			
1	1	0	1	D	CR				-	=	M]	m	}		
1	1	1	0	E	(SO)(RS)				.	>	N	^	n	~		
1	1	1	1	F	SI (US)				/	?	O	-	o	⌋		

9. SAMPLE PROGRAM

1. Horizontal Tab

```
100 rem "Horizontal Tab"
110 rem "ESC 1      : Set Horizontal Tab"
120 rem "ESC 2      : Clear All Horizontal Tab"
130 rem "ESC 8      : Clear Individual Horizontal Tab Stop"
140 rem "ESC HT n   : Absolute Horizontal Tab Stop"
150 open4,4
160 esc$=chr$(27):ht$=chr$(9)
170 a$="1234567890":n$="" :fori=1to7:n$=n$+a$:next
180 dim ht$(5):ht$(0)="" :fori=1to5:ht$(i)=ht$(i-1)+chr$(9):next
190 p$="Horizontal"
200 print#4,n$
210 gosubl000
220 for i=1 to 4:print#4,ht$(i)p$:next
230 fori=1to3:gosubl100:print#4,ht$(1)p$:next
240 gosubl000
250 for i=1 to 4:print#4,ht$(i)p$:next
260 gosubl200
270 fori=1to3:print#4,ht$(1)p$:next
280 gosubl200
290 close4:end
1000 rem "Set Horizontal Tab Stop"
1010 for i=1to4
1020 print#4,esc$;ht$;chr$(i*15);
1030 print#4,esc$"1";
1040 next
1050 print#4
1060 return
1100 rem "Clear Individual Horizontal Tab Stop"
1110 print#4,esc$;ht$;chr$(i*15);
1120 print#4,esc$"8";
1130 return
1200 rem "Clear All Horizontal Tabs"
1210 print#4,esc$"2";
1220 return
```

Result:

```
1234567890123456789012345678901234567890123456789012345678901234567890
      Horizontal
                Horizontal
                          Horizontal
                                Horizontal
                Horizontal
                          Horizontal
                                Horizontal
      Horizontal
                Horizontal
                          Horizontal
                                Horizontal
      orizontal
      orizontal
      orizontal
```

2. Set Left Margin

```
100 rem "ESC 9      : Set Left Mergin"
110 rem "ESC CR P : Remote Reset"
120 open4,4
130 esc$=chr$(27):cr$=chr$(13)
135 a$= "ESC 9      : Set Left Mergin"
137 b$= "ESC CR P : Remote Reset"
140 p$="1234567890":lm$="<left Margin"
150 print#4,esc$cr$"p"
160 for i=1 to 6: print#4,p$;: next:print#4
170 print#4,spc(10);
180 print#4,esc$"9"
190 print#4,lm$
200 print#4,"ESC 9 : Set Left Mergin"
210 print#4,esc$cr$"p"
220 print#4,"ESC CR P : Remote Reset"
230 close4
```

Result (Note the carriage position):

123456789012345678901234567890123456789012345678901234567890

<left Margin
ESC 9 : Set Left Mergin

ESC CR P : Remote Reset

3. Set Lines per Page & etc.

```
100 rem "ESC FF n : Set lines per page to n"
110 rem "ESC L      : Set Bottom Page Margin "
120 rem "ESC T      : Set Top Page Margin  "
130 rem "ESC C      : Clear Top and Bottom Margins"
140 open4,4
150 esc$=chr$(27):ff$=chr$(12):vt$=chr$(11)
160 p$="Commodore Model 6400"
170 print#4,esc$ff$chr$(16);
180 print#4,esc$vt$chr$(5);           :rem "Set
190 print#4,esc$"T"                   :rem "Top Page"
200 print#4,esc$vt$chr$(14);         :rem "Set
210 print#4,esc$"L"                   :rem "Bottom Page"
220 print#4
230 print#4,esc$vt$chr$(5);
240 for i=1 to 26
250 print#4,i;p$
260 next
270 print#4,ff$                       :rem form feed to next page
280 print#4,esc$"C"                   :rem "Clear Top and Bottom Margins"
290 cmd4:list
```

Result:

```
1 Commodore Model 6400
2 Commodore Model 6400
3 Commodore Model 6400
4 Commodore Model 6400
5 Commodore Model 6400
6 Commodore Model 6400
7 Commodore Model 6400
8 Commodore Model 6400
9 Commodore Model 6400
10 Commodore Model 6400
```

```
11 Commodore Model 6400
12 Commodore Model 6400
13 Commodore Model 6400
14 Commodore Model 6400
15 Commodore Model 6400
16 Commodore Model 6400
17 Commodore Model 6400
18 Commodore Model 6400
19 Commodore Model 6400
20 Commodore Model 6400
```

```

21 Commodore Model 6400
22 Commodore Model 6400
23 Commodore Model 6400
24 Commodore Model 6400
25 Commodore Model 6400
26 Commodore Model 6400

```

```

100 rem "ESC FF n : Set lines per page to n"
110 rem "ESC L      : Set Bottom Page Margin "
120 rem "ESC T      : Set Top Page Margin  "
130 rem "ESC C      : Clear Top and Bottom Margins"
140 open4,4
150 esc$=chr$(27):ff$=chr$(12):vt$=chr$(11)
160 p$="Commodore Model 6400"
170 print#4,esc$ff$chr$(16);
180 print#4,esc$vt$chr$(5);           :rem "Set
190 print#4,esc$"T"                   :rem "Top Page"
200 print#4,esc$vt$chr$(14);         :rem "Set
210 print#4,esc$"L"                   :rem "Bottom Page"
220 print#4
230 print#4,esc$vt$chr$(5);
240 for i=1 to 26
250 print#4,i;p$
260 next
270 print#4,ff$                       :rem form feed to next page
280 print#4,esc$"C"                   :rem "Clear Top and Bottom Margins"
290 cmd4:list

```

4. Backward Print, Forward Print

```
100 rem "ESC 5 : Forward Print Mode ON"
110 rem "ESC 6 : Backward Print Mode Set"
120 open4,4
130 esc$=chr$(27):ht$=chr$(9)
140 a$="Forward Print Mode ON"
150 b$="Backward Print Mode ON"
160 sp$=" "
170 for i=1 to 5
180 print#4,esc$ht$chr$(63);
190 print#4,esc$"6"; :rem "Backward Print"
200 print#4,b$sp$;
210 print#4,esc$"5"; :rem "Forward Print"
220 print#4,a$
230 print#4,esc$ht$chr$(63);
240 next
250 print#4
260 print#4,esc$ht$chr$(63);
270 print#4,esc$"6"; :rem "Backward Print"
280 print#4,b$sp$
290 print#4,a$
300 close4
```

Result:

```
Forward Print Mode ON NO edoM tnirP drawkcaB
Forward Print Mode ON NO edoM tnirP drawkcaB
Forward Print Mode ON NO edoM tnirP drawkcaB
Forward Print Mode ON NO edoM tnirP drawkcaB
Forward Print Mode ON NO edoM tnirP drawkcaB
Forward Print Mode ON NO edoM tnirP drawkcaB
```

5. Negative Line Feed

```
100 rem "ESC LF : Negative Line Feed"
110 open4,4
120 esc$=chr$(27):lf$=chr$(10)
130 for i=32to93:a$=a$+chr$(i):next
140 for j=1 to 10 step3
150 for i=1 to j
160 print#4,esc$lf$;
170 print#4,a$
180 next
190 print#4
200 next
210 close4
```

Result:

```
!"#$%&'()*+,-./0123456789:;<=>?@abcdefghijklmnopqrstuvwxyz[\]
!"#$%&'()*+,-./0123456789:;<=>?@abcdefghijklmnopqrstuvwxyz[\]
!"#$%&'()*+,-./0123456789:;<=>?@abcdefghijklmnopqrstuvwxyz[\]
!"#$%&'()*+,-./0123456789:;<=>?@abcdefghijklmnopqrstuvwxyz[\]
```

6. Half Line Feed

```
100 rem "ESC D : Negative Half Line Feed"
110 rem "ESC U : Half Line Feed"
120 open4,4
130 esc$=chr$(27):lf$=chr$(10)
140 for i=1 to 5
150 print#4,"Line Feed"
160 next
170 for i=1 to 5
180 print#4,esc$"U";
190 print#4,"+Half Line Feed"
200 next
210 for i=1 to 5
220 print#4,esc$"D";
230 print#4,"-Half Line Feed"
240 next
250 close4
```

Result:

```
Line Feed
Line Feed
Line Feed
Line Feed
Line Feed

+Half Line Feed
+Half Line Feed
+Half Line Feed
+Half Line Feed

+Half Line Feed
+Half Line Feed
+Half Line Feed
+Half Line Feed
```

7. HMI, VMI

```
100 rem "ESC US n : Set Horizontal Motion Index(HMI) to n-1"
110 rem "ESC RS n : Set Vertical Motion Index(VMI) to n-1"
115 rem "ESC S      : Reset HMI to Value specified by SW414"
120 open4,4
130 esc$=chr$(27):us$=chr$(31):rs$=chr$(30)
140 p$="commodore model 6400"
150 fori=0to9
160 print#4,esc$us$chr$(10+3*i);      :rem "Set HMI to n-1 "
170 print#4,esc$rs$chr$(6+2*i);      :rem "Set VMI to n-1 "
180 print#4,p$
190 next
200 print#4,esc$"s";
210 print#4,esc$rs$chr$(9);          :rem "Initial HMI"
220 close4                          :rem "Initial VMI"
```

Result:

```
commodore model 6400
commodore model 6400
commodore model 6400
commodore model 6400
commodore model 6400
commodore model 6400
commodore model 6400
commodore model 6400
commodore model 6400
commodore model 6400
```

8. Absolute Vertical Tab

```

100 rem "ESC VT n : Set Absolute Vertical Tab Stop"
110 open 4,4
120 esc$=chr$(27):vt$=chr$(11):ff$=chr$(12)
130 p$="vertical":p=len(p$)
140 for i=1 to 15+p
150 print#4,esc$vt$chr$(i);
160 print#4,i
170 next
180 for i=1 to 15
190 print#4,esc$vt$chr$(i);
200 for j=1 to p:print#4,spc(i+2)mid$(p$,j,1):next
210 next
220 for i= 16 to 30
230 print#4,esc$vt$chr$(31-i);
240 for j=1 to p:print#4,spc(i+1)mid$(p$,j,1):next
250 next
260 print#4,esc$vt$chr$(15+p);
270 print#4
280 print#4,esc$vt$chr$(1);
290 for j=1 to p:print#4,spc(15+2)mid$(p$,j,1):next
300 print#4
310 print#4,ff$
320 close4

```

Result:

```

1 v          v          v
2 ev        e          ve
3 rev       r          ver
4 trev      t          vert
5 itrev     i          verti
6 citrev    c          vertic
7 acitrev   a          vertica
8 lacitrev  l          vertical
9  lacitrev          vertical
10 lacitrev          vertical
11  lacitrev          vertical
12   lacitrev          vertical
13    lacitrev          vertical
14     lacitrev          vertical
15      lacitre          vertical
16       lacitrertical
16       lacitrertical
17        lacitrtical
18         lacitical
19          lacical
20           lacal
21            lal
22             l
23

```

9. ESC Y, ESC Z

```
100 rem "ESC Y: Printing a character at potion 14 of print wheel"  
110 rem "ESC Z: Printing a character at potion 13 of print wheel"  
120 open4,4  
130 esc$=chr$(27)  
140 fori=1to30:print#4,esc$"Y";:next  
150 print#4  
160 fori=1to30:print#4,esc$"Z";:next  
170 close4
```

Result:

```
EEEEEEEEEEEEEEEEEEEEEEEEEEEEEEEEEEEE  
rrrrrrrrrrrrrrrrrrrrrrrrrrrrrrrrrr
```

10. Bi-directional Printing

```
100 rem "ESC / : Enable Bi-directional Printing"
110 rem "ESC\ : Disable Bi-directional Printing"
120 open4,4
130 esc$=chr$(27)
140 a$="Enable Bi-directional Printing"
150 b$="Disable Bi-directional Printing"
160 print#4,esc$"/";      :rem "Enable Bi-directional Printing"
170 for i=1 to 5
180 print#4,a$
190 next
200 print#4,esc$"\";      :rem "Disable Bi-directional Printing"
210 for i=1 to 5
220 print#4,b$
230 next
240 close4
```

Result:

```
Enable Bi-directional Printing
Enable Bi-directional Printing
Enable Bi-directional Printing
Enable Bi-directional Printing
Enable Bi-directional Printing
Disable Bi-directional Printing
Disable Bi-directional Printing
Disable Bi-directional Printing
Disable Bi-directional Printing
Disable Bi-directional Printing
```

11. Proportional Space

```
100 rem "ESC P : Proportional Space ON"
110 rem "ESC Q : Proportional Space OFF"
120 rem "ESC S : Proportional Space Clear"
130 open4,4
140 esc$=chr$(27)
150 a$="Proportional Space ON"
160 b$="Proportional Space OFF"
170 for i=1 to 5
180 print#4,esc$"P";           :rem "Proportional Space ON"
190 print#4,a$;" ";a$
200 print#4,esc$"Q";           :rem "Proportional Space OFF"
210 print#4,b$;" ";b$
220 next
230 print#4
240 print#4,esc$"P";           :rem "Proportional Space ON"
250 print#4,a$;" ";a$
260 print#4,esc$"S";           :rem "Proportional Space clear"
270 print#4,b$;" ";b$
280 print#4
290 close4
```

Result:

```
Proportional Space ON  Proportional Space ON
Proportional Space OFF Proportional Space OFF
Proportional Space ON  Proportional Space ON
Proportional Space OFF Proportional Space OFF
Proportional Space ON  Proportional Space ON
Proportional Space OFF Proportional Space OFF
Proportional Space ON  Proportional Space ON
Proportional Space OFF Proportional Space OFF
Proportional Space ON  Proportional Space ON
Proportional Space OFF Proportional Space OFF

Proportional Space ON  Proportional Space ON
Proportional Space OFF Proportional Space OFF
```

12. Offset Selection

```
100 rem "ESC DC1 n : Offset Selection"
110 open4,4
120 esc$=chr$(27):dcl$=chr$(17)
130 a$= "ESC DC1":b$=": Offset Selection"
140 c$= " :rem Clear Offset Selection"
150 print#4,esc$"P";"FOR Proportional Space Printing"
160 for j=0 to 12
170 print#4,esc$dcl$chr$(j);a$;j;b$
180 next
190 print#4,esc$dcl$chr$(1*64+j);a$;64+j;b$
200 print#4,esc$dcl$chr$(j)esc$"X";a$;j;b$;c$" by ESC X"
210 print#4,esc$dcl$chr$(j)
220 print#4,a$;j;b$;c$" by CR"
230 close4
```

Result:

```
FOR Proportional Space Printing
ESC DC1 0 : Offset Selection
ESC DC1 1 : Offset Selection
ESC DC1 2 : Offset Selection
ESC DC1 3 : Offset Selection
ESC DC1 4 : Offset Selection
ESC DC1 5 : Offset Selection
ESC DC1 6 : Offset Selection
ESC DC1 7 : Offset Selection
ESC DC1 8 : Offset Selection
ESC DC1 9 : Offset Selection
ESC DC1 10 : Offset Selection
ESC DC1 11 : Offset Selection
ESC DC1 12 : Offset Selection
S07:60
ESC DC1 13 : Offset Selection :rem Clear Offset Selection by ESC X
ESC DC1 13 : Offset Selection :rem Clear Offset Selection by CR
```

13. Underscore

```
100 rem "ESC E : Auto Underscore ON"
110 rem "ESC R : Auto Underscore OFF"
120 open4,4
130 esc$=chr$(27)
140 for i=65 to 90 :a$=a$+chr$(i):next
150 for i=193 to 218 :a$=a$+chr$(i):next
160 for i=1 to 5
170 print#4,esc$"E"; :rem "Auto Underscore ON"
180 print#4,a$
190 print#4,esc$"R"; :rem "Auto Underscore OFF"
200 print#4,a$
210 next
220 close4
```

Result:

abcdefghijklmnopqrstuvwxyzABCDEFGHIJKLMNOPQRSTUVWXYZ
abcdefghijklmnopqrstuvwxyzABCDEFGHIJKLMNOPQRSTUVWXYZ
abcdefghijklmnopqrstuvwxyzABCDEFGHIJKLMNOPQRSTUVWXYZ
abcdefghijklmnopqrstuvwxyzABCDEFGHIJKLMNOPQRSTUVWXYZ
abcdefghijklmnopqrstuvwxyzABCDEFGHIJKLMNOPQRSTUVWXYZ
abcdefghijklmnopqrstuvwxyzABCDEFGHIJKLMNOPQRSTUVWXYZ
abcdefghijklmnopqrstuvwxyzABCDEFGHIJKLMNOPQRSTUVWXYZ
abcdefghijklmnopqrstuvwxyzABCDEFGHIJKLMNOPQRSTUVWXYZ
abcdefghijklmnopqrstuvwxyzABCDEFGHIJKLMNOPQRSTUVWXYZ

14. Bold, Shadow Print

```
100 rem "ESC O : Bold Print Mode ON"
110 rem "ESC W : Shadow Print Mode ON"
120 rem "ESC & : Bold/Shadow Print Mode ON"
130 open4,4
140 esc$=chr$(27)
150 for i=33 to 93 : a$=a$+chr$(i):next
160 print#4,esc$"O";"Bold Print ON"
170 for i=1 to 4
180 print#4,esc$"O";a$
190 next
200 print#4
210 print#4,esc$"W";"Shadow Print ON"
220 for i=1 to 4
230 print#4,esc$"W";a$
240 next
250 print#4
260 print#4,esc$"&";"Bold/Shadow Print OFF"
270 for i=1 to 5
280 print#4,a$
290 next
300 close4
```

Result:

Bold Print ON

```
!"#$%&'()*+,-./0123456789:;<=>?@abcdefghijklmnopqrstuvwxyz[\]
!"#$%&'()*+,-./0123456789:;<=>?@abcdefghijklmnopqrstuvwxyz[\]
!"#$%&'()*+,-./0123456789:;<=>?@abcdefghijklmnopqrstuvwxyz[\]
!"#$%&'()*+,-./0123456789:;<=>?@abcdefghijklmnopqrstuvwxyz[\]
```

Shadow Print ON

```
!"#$%&'()*+,-./0123456789:;<=>?@abcdefghijklmnopqrstuvwxyz[\]
!"#$%&'()*+,-./0123456789:;<=>?@abcdefghijklmnopqrstuvwxyz[\]
!"#$%&'()*+,-./0123456789:;<=>?@abcdefghijklmnopqrstuvwxyz[\]
!"#$%&'()*+,-./0123456789:;<=>?@abcdefghijklmnopqrstuvwxyz[\]
```

Bold/Shadow Print OFF

```
!"#$%&'()*+,-./0123456789:;<=>?@abcdefghijklmnopqrstuvwxyz[\]
!"#$%&'()*+,-./0123456789:;<=>?@abcdefghijklmnopqrstuvwxyz[\]
!"#$%&'()*+,-./0123456789:;<=>?@abcdefghijklmnopqrstuvwxyz[\]
!"#$%&'()*+,-./0123456789:;<=>?@abcdefghijklmnopqrstuvwxyz[\]
!"#$%&'()*+,-./0123456789:;<=>?@abcdefghijklmnopqrstuvwxyz[\]
```

15. Carriage Settling Time

```
100 rem "ESC % : Carriage Settling Time Control"
110 rem "ESC N : Carriage Settling Time Control Clear"
120 open4,4
130 esc$=chr$(27)
140 a$= "ESC % : Carriage Settling Time Control"
150 b$= "ESC N : Carriage Settling Time Control Clear"
160 print#4,esc$"%"
170 for j=0 to 4
180 print#4,a$
190 next
200 print#4,esc$"N"
210 for j=0 to 4
220 print#4,b$
230 next
240 close4
```

Result (Notice different delays):

```
ESC % : Carriage Settling Time Control
ESC % : Carriage Settling Time Control
ESC % : Carriage Settling Time Control
ESC % : Carriage Settling Time Control
ESC % : Carriage Settling Time Control

ESC N : Carriage Settling Time Control Clear
ESC N : Carriage Settling Time Control Clear
ESC N : Carriage Settling Time Control Clear
ESC N : Carriage Settling Time Control Clear
ESC N : Carriage Settling Time Control Clear
```

16. Program Mode

```
100 rem "ESC SO M : Program Mode ON"
110 rem "SI      : Program Mode OFF"
120 open4,4
130 esc$=chr$(27):so$=chr$(14):si$=chr$(15)
140 print#4,esc$so$"M"
150 for i=15 to 1 step-1
160 print#4,chr$(221);chr$(i);
170 print#4,chr$(221)
180 print#4
190 next
200 print#4,si$
210 cmd4:list
```

Result:

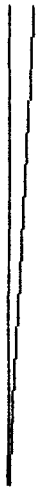

```
100 rem "ESC SO M : Program Mode ON"
110 rem "SI      : Program Mode OFF"
120 open4,4
130 esc$=chr$(27):so$=chr$(14):si$=chr$(15)
140 print#4,esc$so$"M"
150 for i=15 to 1 step-1
160 print#4,chr$(221);chr$(i);
170 print#4,chr$(221)
180 print#4
190 next
200 print#4,si$
210 cmd4:list
ready.
```

17. Cancel All WP Modes

```
100 rem "ESC X: Cancel All WP Modes"
110 open4,4
120 esc$=chr$(27)
130 fori=48to93 :a$=a$+chr$(i):next
140 print#4,esc$"P";"Proportinal Space"
150 print#4,"ESC P      : ";esc$"P";a$
160 print#4,"ESC P ESC X: ";esc$"P"esc$"X";a$
170 print#4,esc$"O";"Bold Print"
180 print#4,"ESC O      : ";esc$"O";a$
190 print#4,"ESC O ESC X: ";esc$"O"esc$"X";a$
200 print#4,esc$"W";"Shadow Print"
210 print#4,"ESC W      : ";esc$"W";a$
220 print#4,"ESC W ESC X: ";esc$"W"esc$"X";a$
230 print#4,esc$"E";"Auto Underscore"
240 print#4,"ESC E      : ";esc$"E";a$
250 print#4,"ESC E ESC X: ";esc$"E"esc$"X";a$
```

Result:

```
Proportinal Space
ESC P      : 0123456789:;<=>?@abcdefghijklmnopqrstuvwxyz[\]
ESC P ESC X: 0123456789:;<=>?@abcdefghijklmnopqrstuvwxyz[\]
Bold print
ESC O      : 0123456789:;<=>?@abcdefghijklmnopqrstuvwxyz[\]
ESC O ESC X: 0123456789:;<=>?@abcdefghijklmnopqrstuvwxyz[\]
Shadow Print
ESC W      : 0123456789:;<=>?@abcdefghijklmnopqrstuvwxyz[\]
ESC W ESC X: 0123456789:;<=>?@abcdefghijklmnopqrstuvwxyz[\]
Auto Underscore
ESC E      : 0123456789:;<=>?@abcdefghijklmnopqrstuvwxyz[\]
ESC E ESC X: 0123456789:;<=>?@abcdefghijklmnopqrstuvwxyz[\]
```

18. Backspace 1/120

```
100 rem "ESC BS: Backspace 1/120"  
110 open4,4  
120 esc$=chr$(27):bs$=chr$(8)  
130 for i=1 to 60  
140 print#4,chr$(221)esc$bs$;  
150 next  
160 print#4  
170 for i=1 to 60  
180 print#4,chr$(221);  
190 next  
200 print#4  
210 close4
```

Result:



19. Back Space

```
100 rem "BS : Back Space"  
110 open4,4  
120 bs$=chr$(8)  
130 a$= "BS : Back Space" :dim bs$(len(a$))  
140 bs$(0)="" :for i=1 to len(a$) :bs$(i)=bs$(i-1)+bs$:next  
150 for i=1 to len(a$)  
160 print#4,spc(40);  
170 print#4,bs$(i)mid$(a$,i,1)  
180 next  
190 close4
```

Result:

```
          B  
          S  
          :  
         B  
        a  
       c  
      k  
     S  
    p  
   a  
  c  
 e
```

20. Carriage Return, Carriage Stand, Space

```
100 rem "CR : Carriage Return"
110 rem "CS : Carriage Stand"
120 rem "SP : Space"
130 open4,4
140 cr$=chr$(13):cs$=chr$(141):sp$=chr$(32)
150 a$= "CR : Carriage Return"
160 b$= "CS : Carriage Stand"
170 c$= "SP : Space"
180 print#4,a$cr$;
190 print#4,c$sp$sp$sp$sp$sp$c$
200 print#4,b$cs$b$cs$b$cs$b$cr$b$cs$b$cs$b$cr$
210 close4
```

Result:

```
CR : Carriage Return
SP : Space      SP : Space
CS : Carriage Stand
CS : Carriage Stand
```

 **commodore**
COMPUTER

PRINTED IN JAPAN
E1-1684C 83101500 © D